

EBC-2000 Series
All-in-one Socket-370 Based Networking Engine
User's Guide



Recycled Paper

©Copyright 2002 ADLINK Technology Inc.

Manual Rev. 1.00 : March, 11, 2002

Part NO: 50-13029-100

The information in this document is subject to change without prior notice in order to improve reliability, design and function and does not represent a commitment on the part of the manufacturer.

In no event will the manufacturer be liable for direct, indirect, special, incidental, or consequential damages arising out of the use or inability to use the product or documentation, even if advised of the possibility of such damages.

This document contains proprietary information protected by copyright. All rights are reserved. No part of this manual may be reproduced by any mechanical, electronic, or other means in any form without prior written permission of the manufacturer.

Trademarks

NuPRO is a registered trademark of ADLINK Technology Inc.,

Other product names mentioned herein are used for identification purposes only and may be trademarks and/or registered trademarks of their respective companies.

Getting service from ADLINK

- Customer Satisfaction is always the most important thing for ADLINK Tech Inc. If you need any help or service, please contact us and get it.

ADLINK Technology Inc.			
Web Site	http://www.adlinktech.com		
Sales & Service	service@adlinktech.com		
Technical Support	NuDAQ + USBDAQ	nudaq@adlink.com.tw	
	NuDAM	nudam@adlink.com.tw	
	NuIPC	nuipc@adlink.com.tw	
	NuPRO / EBC	nupro@adlink.com.tw	
	Software	sw@adlink.com.tw	
TEL	+886-2-82265877	FAX	+886-2-82265717
Address	9F, No. 166, Jian Yi Road, Chungho City, Taipei, 235 Taiwan, R.O.C.		

- Please inform or FAX us of your detailed information for a prompt, satisfactory and constant service.

Detailed Company Information			
Company/Organization			
Contact Person			
E-mail Address			
Address			
Country			
TEL		FAX	
Web Site			
Questions			
Product Model			
Environment to Use	OS:		
	Computer Brand:		
	M/B:	CPU:	
	Chipset:	BIOS:	
	Video Card:		
	Network Interface Card:		
	Other:		
Challenge Description			
Suggestions to ADLINK			

Table of Contents

Chapter 1 Introduction	1
1.1 Checklist.....	2
1.2 Description.....	2
1.3 Features	2
1.4 Specifications.....	4
1.5 Intelligence.....	7
1.6 PCB Layout Drawing.....	8
1.7 Mechanical Drawing.....	9
Chapter 2 Installation	10
2.1 CPU Installation	10
2.2 Memory Installation.....	11
2.3 Jumpers on the EBC-2000.....	11
Chapter 3 Watchdog Programming.....	22
3.1 Disk On Chip Address.....	25
Chapter 4 VIA VT82C694T Chipset Service Pack (VIA 4 In 1) Installation	26
Chapter 5 LAN Driver Installation	29
5.1 Software and Drivers Support.....	29
5.2 Driver Installation on Windows 2000.....	30
5.3 Driver Installation on Windows 98.....	31
5.4 Driver Installation on Windows NT.....	32
Product Warranty/Service	35

How to Use This Guide

This manual is designed to help you to use the EBC-2000 series.

- Chapter 1, “Introduction”** gives an overview of the product features and specifications.
- Chapter 2, “Installation”** describes how to install the SBC. The PCB layout, jumper setting and connector pin assignments are shown.
- Chapter 3 “Watchdog Programming** shows the functionality of the watchdog timer.
- Chapter 4, “VIA Pro133T Hardware Driver”** describes how to install the VGA and Hardware drivers of the VIA Pro133T chipset.
- Chapter 5, “LAN driver installation”** describes how to install the LAN driver for EBC-2000 SBC.

EBC-2000 Series Function List

Model	EBC-2000T	EBC-2000D	EBC-2000L
Processor	Pentium III / Celeron / C3	Pentium III / Celeron / C3	Pentium III / Celeron / C3
Chipset	VIA Pro133T	VIA Pro133T	VIA Pro133T
BIOS	Award	Award	Award
Max. SDRAM	512MB un-buffered (ECC/Non-ECC)	512MB un-buffered (ECC/Non-ECC)	512MB un-buffered (ECC/Non-ECC)
Memory Sockets	1 x DIMM	1 x DIMM	1 x DIMM
Ethernet (10/100Mbps)	Trip LAN (i82559)	Dual LAN (i82559)	Single LAN (i82559)
MiniPCI	Yes	Yes	Yes
PCI Golden Finger	Yes	Yes	Yes
DiskOnChip	Yes	Yes	Yes
Multi I/O Chip	Built-in VIA 686B	Built-in VIA 686B	Built-in VIA 686B
Enhanced IDE (ATA-100)	Yes	Yes	Yes
COM 1&2 / LPT	Yes	Yes	Yes
COM 3&4	Yes	No	No
USB	Yes	Yes	Yes
IrDA	Yes	Yes	Yes
Audio	Optional Module	Optional Module	Optional Module
LCM I/F	Yes	Yes	Yes
User Data EEPROM	Yes	Yes	Yes
H/W Monitoring	Yes	Yes	Yes

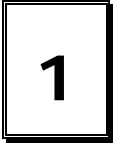

Introduction

This manual is designed to give you information on the EBC-2000 series Single Board Computer. The information inside this user's manual can be applied to EBC-2000 series if without specified.

The topics covered in this chapter are as follows:

- Checklist
- Description
- Features
- Specifications
- Intelligence
- PCB Layout Drawing
- Mechanical Drawing

1.1 Checklist

Please check that your package is complete and contains the items below. If you discover damaged or missing items, please contact your dealer.

- The EBC-2000 Network Engine Computing Board
- This User's Manual
- RJ-45 board(s) & cable(s) for Ethernet connection
- 1 CD Containing hardware configuration file, VGA Driver, LAN Driver and Hardware Monitor utility

1.2 Description

The EBC-2000 is a VIA Pro133T based Networking Engine Computing Board with the VIA Pro133T chipset and is fully designed for harsh networking environment. It built-in three high speed 10/100Mbps Ethernet. This board accommodates up to 512MB SDRAM configuration.

The hardware monitoring device is built-in on the system chipset which monitors system and CPU temperature, system voltages.

1.3 Features

- Supports Socket-370 based Intel Pentium III / Celeron (FC-PGA & FC-PGA2) & VIA C3 CPU up to 133MHz FSB
- VIA Pro133T (VT82C694T + VT82C686B) chipset
- Up to 512MB SDRAM system memory (1 x 168-pin DIMM sockets); supports ECC/Non-ECC SDRAM
- Dual IDE Channels support up to Ultra/DMA100
- Two RS-232C interface (One for ADLINK's LCM module only), optional up to four ports
- High speed bi-directional SPP/ECP/EPP parallel port
- Programmable watchdog timer
- Hardware Monitoring
- Max. three Intel 82559 10/100 Base-T Ethernet interface with flexible RJ-45 connectors
- AC'97 Link interface support DB-AC97S board for audio input & output

2 · Introduction

- One 32-bit/33MHz MiniPCI Bus which compatible with most of standard MiniPCI Type III or ADLINK's mPCI add-on cards
- One 32-bit PCI golden finger for system development & extension
- Supports ATX power control function
- External LAN status LED connectors
- Supports M-System DiskOnChip (DOC) Flash disk up to 288MB
- Supports Disk-On-Module (DOM) via IDE port
- Special designed the system cooling for most high performance processor
- 2KB EEPROM user programmable space for most important data such as security information, software protection data

1.4 Specifications

- ◆ **Processor Socket:** Socket-370 connector
- ◆ **Processor:** Intel Celeron and Pentium III (FC-PGA & FC-PGA2), VIA C3 CPU
- ◆ **Secondary Cache: built in CPU**
- ◆ **Bus Speed:** 66/100/133MHz
- ◆ **Chipset:** VIA Pro133T (VT82C694T + VT82C686B)
- ◆ **Memory Sockets:**
 - One 168-pin DIMM sockets
 - Max. 512MB SDRAM
 - Memory type: PC-133 un-buffered ECC/Non-ECC SDRAM
- ◆ **BIOS: Award BIOS, support PnP**
 - 256KB Flash chip for BIOS update
 - DMI BIOS Support: Desktop Management Interface (DMI) allows users to download system hardware-level information such as CPU type, CPU speed, internal/external frequencies and memory size.
 - Green Function: Power management via BIOS, activated through mouse/keyboard movement
- ◆ **PCI Compliance:** Fully compliant to PCI rev. 2.1 standards
- ◆ **PCI Bus Ethernet Interface:**
 - Max. three Intel 82559 PCI local bus Ethernet controllers on board
 - 10/100Mbps operation in a single port PCI bus master architecture
 - IEEE 802.3 10base-T and 100base-TX compatible physical longer support
 - IEEE802.3 μ auto-negotiation support for automatic speed selection
 - IEEE 802.3X (100base-TX Flow control support)
 - External LAN status LED connectors
 - External Ethernet daughter board RJ-45 connector and built-in LAN 0status LED

- ◆ **Enhanced IDE:** Bus Master IDE controller, two EIDE interfaces for up to four devices, support PIO Mode 3/4 or Ultra DMA/100 IDE devices, including Hard Disk Drive, ATAPI CD-ROM, LS120, and ZIP drives.
- ◆ **Super I/O Chipset:** Built-in VT82C686B
- ◆ **Parallel Port:**
 - One high-speed parallel port, SPP/EPP/ECP mode, setting in BIOS
- ◆ **Serial Port:**
 - Three 16550 UART compatible ports with RS-232 interface (only for EBC-2000T)
 - One 16550 UART compatible port for ADLINK's LCM module which uses COM1 interface , the level is 3.3V CMOS level.
- ◆ **FDD Interface:** Two floppy drives (360KB, 720KB, 1.2MB, 1.44MB, 2.88MB)
- ◆ **USB Interface:** Two USB pin-header connectors, compliant with USB Specification Rev. 1.1, Individual over-current protection
- ◆ **AC'97 Link:**
 - One 10 pin connector for DB-AC97S board
- ◆ **2KB User programmable EEPROM:**
 - 2KB User programmable EEPROM to store user data & security information, bundle with C source code for programming reference.
- ◆ **Watchdog Timer:**
 - Programmable I/O port 370h and 371h to configure watchdog timer
 - Time-out timing select 0~255 seconds or 0~255 minutes
- ◆ **Keyboard and Mouse Connectors:**
 - Supports a 6-pin internal keyboard/mouse pin-header connector
- ◆ **Power supply:** Same as 5.25" CD-ROM type (+5V / +12V input)
- ◆ **Environmental:**
 - Storage Temperature: -20°C to 80°C
 - Operation Temperature: 0°C to 55°C
 - Humidity: 5% to 95%

- **Power Requirement:**

Power Type	Value <small>(MAX)</small>	Unit	Note
+5V	15	A	
+12V	650	mA	1

Note : 1. With ADLINK CPU cooler system

System configuration : EBC-2000T, Intel Pentium III/1GHz (133MHz FSB), 512MB (PC-133, ECC) SDRAM x 1

Note: The above values are the maximum power requirement for SBC with CPU and RAM only, the CPU is running under fully loading. The power for all the other peripheral devices such as keyboard, mouse, add-on cards, HDD, or CD ROM is not included.

- ◆ **Dimension:** 210mm x 140mm(8.3" x 5.5")

1.5 Intelligence

- ◆ **System Health Monitoring:**

A sensor for the CPU temperature on the EBC-2000 monitors the CPU temperature, an external sensor for system temperature, case-opened indicator, fan-speed detection, system voltages monitoring.

- ◆ **Windows 98 shut-off:**

Allows shut-off control from within Windows 98 and through an ATX power supply.

1.6 PCB Layout Drawing

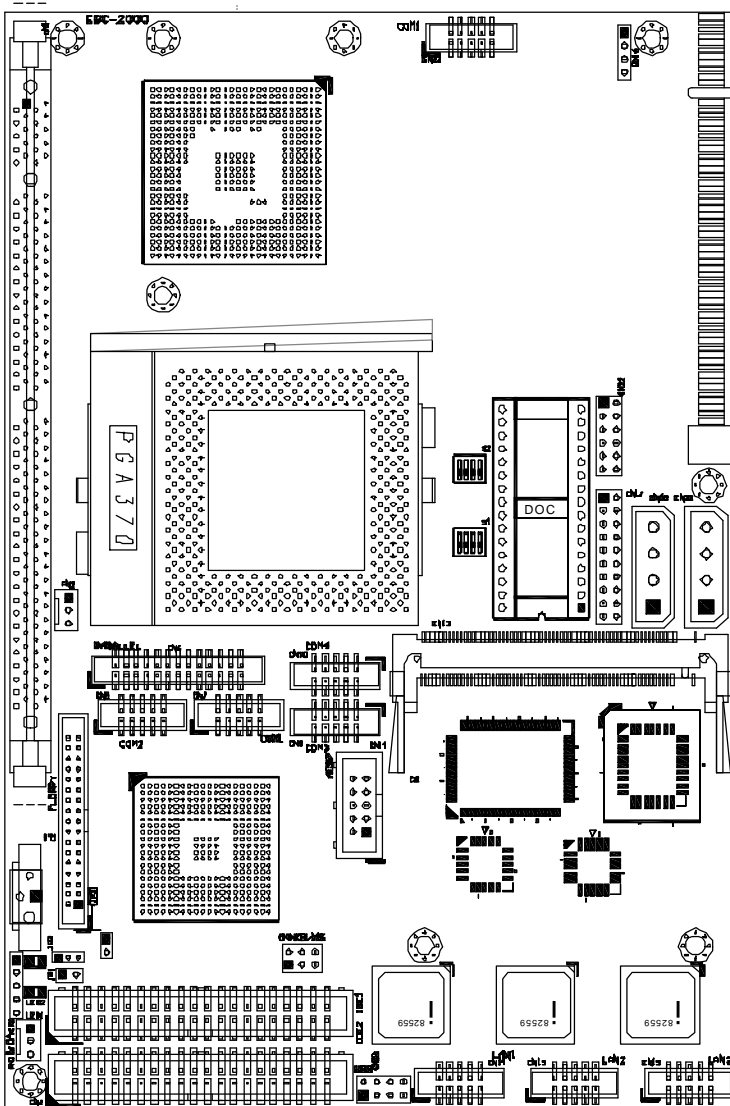

1.7 Mechanical Drawing

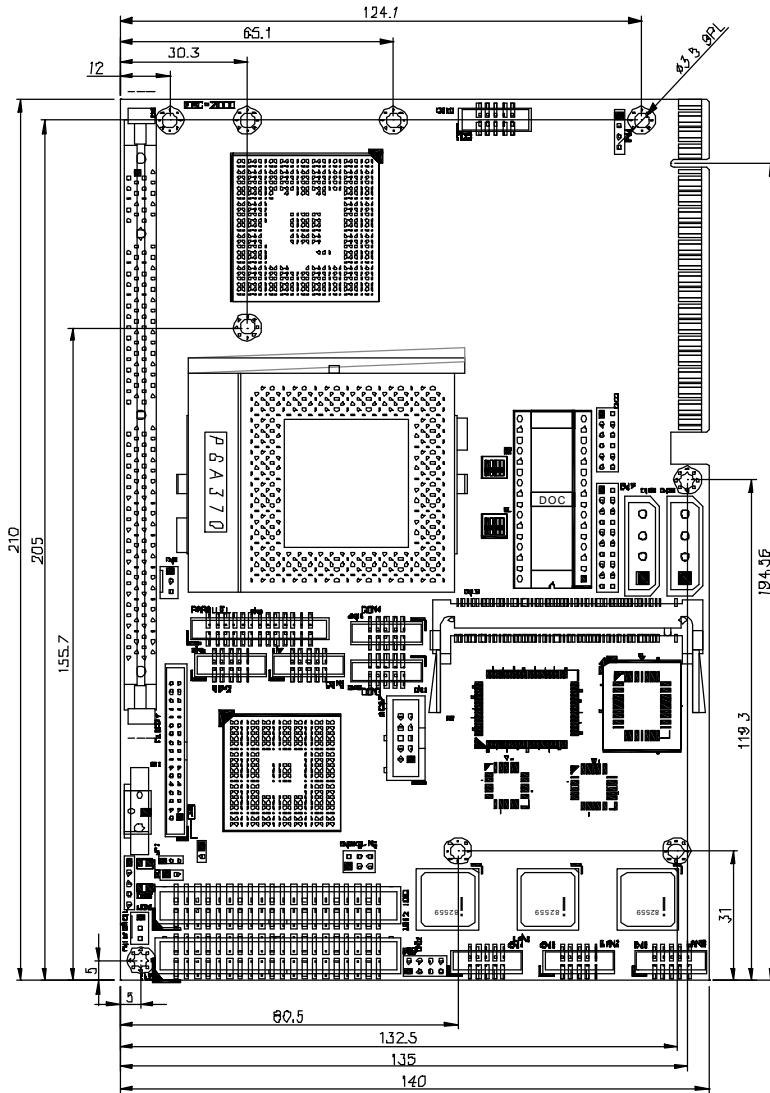

2

Installation

This chapter provides information on how to use the jumpers and connectors on the EBC-2000 in order to set up a workable system. The topics covered are:

- Memory Installation
- Jumpers Setting
- Connectors Pin Assignments

2.1 CPU Installation

The EBC-2000 network computing board supports a Socket-370 processor socket for Intel Celeron, Pentium III (FC-PGA/FC-PGA2) and VIA C3 processors.

Before inserting the CPU, make sure the notch on the corner of the CPU corresponds with the notch on the inside of the socket.

Note: Ensure that the CPU cooler does fully contact with the CPU top surface to avoid CPU overheating that would cause your system to hang or be unstable.

2.2 Memory Installation



The EBC-2000 industrial computer main board supports one 168-pin DIMM sockets for a maximum total memory of 512MB. The memory modules can come in sizes of 32MB, 64MB, 128MB, 256MB and 512MB SDRAM.

2.3 Jumpers on the EBC-2000

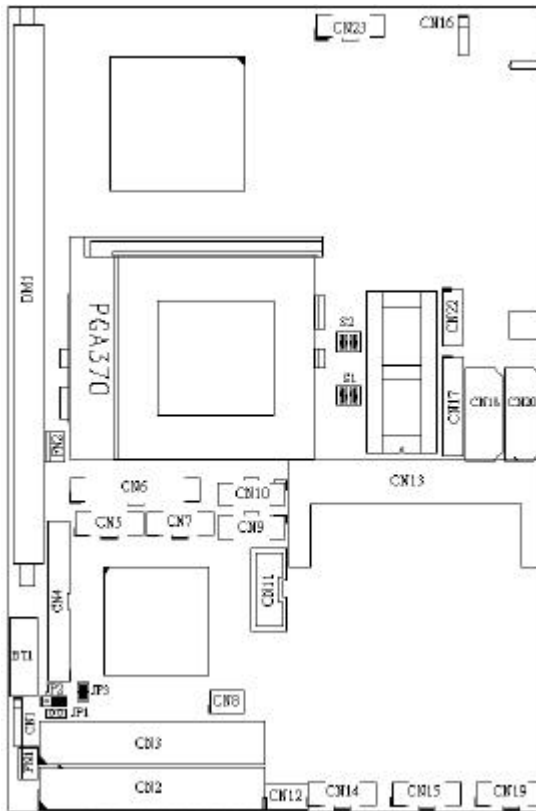
The jumpers on the EBC-2000 allow you to configure your main board according to the needs of your applications. If you have doubts about the best jumper configuration for your needs, contact your dealer or sales representative. The figure and table below show the correct setting to match the CPU frequency.



Clear CMOS Jumper – JP2

JP2	Setting	Function
	Pin 2-3 Short/Closed	Normal operation (Default)
	Pin 1-2 Short/Closed	Clear CMOS Content

Keyboard/Mouse Connector – CN8

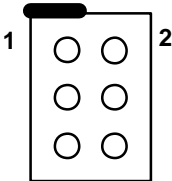

Pin #	Signal Name
1	Keyboard data
2	Keyboard clock
3	Mouse data
4	Mouse clock
5	Vcc
6	GND

LAN RJ45 Connector – CN14, CN15 and CN19

LAN1 ->CN14, LAN2->CN15, LAN3-CN19



Pin #	Signal Name
1	RD+
2	RD-
3	GND
4	SPEED
5	+5V / +5V _{SB}
6	ACT/LINK
7	GND
8	GND
9	TD-
10	TD+

USB Connectors - CN12

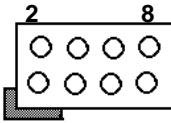

Pin #	Pin #	Signal Name
1	2	Vcc
3	4	USB0-,USB1-
5	6	USB0+, USB1+
7	8	Ground

Parallel Port Connector - CN6

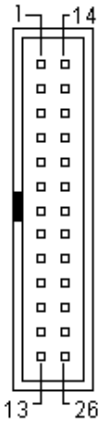

Signal Name	Pin #	Pin #	Signal Name
Line printer strobe	1	14	AutoFeed
PD0, parallel data 0	2	15	Error
PD1, parallel data 1	3	16	Initialize
PD2, parallel data 2	4	17	Select
PD3, parallel data 3	5	18	Ground
PD4, parallel data 4	6	19	Ground
PD5, parallel data 5	7	20	Ground
PD6, parallel data 6	8	21	Ground
PD7, parallel data 7	9	22	Ground
ACK, acknowledge	10	23	Ground
Busy	11	24	Ground
Paper empty	12	25	Ground
Select	13	N/A	N/A

Floppy Connector - CN4

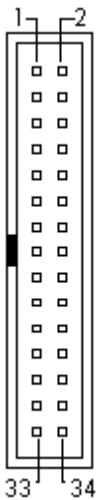

Signal Name	Pin #	Pin #	Signal Name
Ground	1	2	Drive density selection
Ground	3	4	No connect
Ground	5	6	Drive density selection
Ground	7	8	Index
Ground	9	10	Motor enable 0
Ground	11	12	Drive select 1
Ground	13	14	Drive select 0
Ground	15	16	Motor enable 1
Ground	17	18	Direction
Ground	19	20	Step
Ground	21	22	Write data
Ground	23	24	Write gate
Ground	25	26	Track 00
Ground	27	28	Write protect
Ground	29	30	Read data
Ground	31	32	Side 1 select
Ground	33	34	Diskette change

IrDA Connector - CN1



PIN #	Signal Name
1	+5V
2	NC
3	IRRXD
4	GND
5	IRTXD

SM Bus Connector - CN16



PIN #	Signal Name
1	GND
2	+5V
3	SMCLK
4	SMDATA

CPU Fan Power Connector - FN2



Pin #	Signal Name
1	Ground
2	+12V
3	Rotation

External Fan Power Connector - FN1



Pin #	Signal Name
1	Ground
2	+12V
3	Rotation

COM Serial Ports – CN7, CN5, CN9 and CN10

COM1 -> CN23 , COM2->CN5, COM3-> CN9,COM4-> CN10

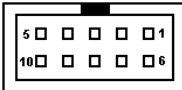

Pin #	Signal Name
1	DCD, Data carrier detect
2	RXD, Receive data
3	TXD, Transmit data
4	DTR, Data terminal ready
5	GND, ground
6	DSR, Data set ready
7	RTS, Request to send
8	CTS, Clear to send
9	RI, Ring indicator
10	NC

LCM Serial Port - CN23

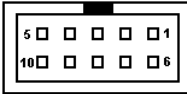

Pin #	Signal Name
1	DCD, Data carrier detect
2	RXD, Receive data
3	TXD, Transmit data
4	DTR, Data terminal ready
5	GND, ground
6	DSR, Data set ready
7	RTS, Request to send
8	CTS, Clear to send
9	RI, Ring indicator
10	+5V

AC97 Link Port - CN11

This connector is an optional function which can be connected to the DB-AC97s board for AC'97 audio in/out. DB-AC97S support Line-in, Line-Out, CDROM-in connector. Please contact with ADLINK's reseller for this board.

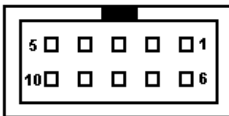

Pin #	Signal Name
1	GND
2	GND
3	+5V
4	+5V
5	AC_SYNC
6	AC_CLK
7	AC_SDIN0
8	AC_SDOUT
9	AC_SDIN1
10	AC_RST#

DiskOnChip (DOC) socket : U10 (DOC)

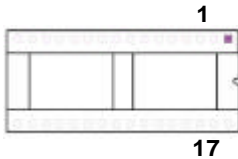

IDE Ports

IDE1: Primary IDE Connector

IDE2: Secondary IDE Connector

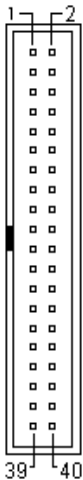

Signal Name	Pin #	Pin #	Signal Name
Reset IDE	1	2	Ground
Host data 7	3	4	Host data 8
Host data 6	5	6	Host data 9
Host data 5	7	8	Host data 10
Host data 4	9	10	Host data 11
Host data 3	11	12	Host data 12
Host data 2	13	14	Host data 13
Host data 1	15	16	Host data 14
Host data 0	17	18	Host data 15
Ground	19	20	+5V for DOM
DRQ0	21	22	Ground
Host IOW	23	24	Ground
Host IOR	25	26	Ground
IOCHRDY	27	28	Host ALE
DACK0	29	30	Ground
IRQ14/15	31	32	No connect
Address 1	33	34	80P DET
Address 0	35	36	Address 2
Chip select 0	37	38	Chip select 1
Activity	39	40	Ground

External LAN LED interface - CN22

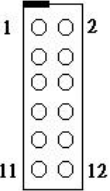

Pin #	Signal Name
1	LAN1 SPEED
2	+5V
3	LAN1 LINK/ACT
4	+5V
5	LAN2 SPEED
6	+5V
7	LAN2 LINK/ACT
8	+5V
9	LAN3 SPEED
10	+5V
11	LAN3 LINK/ACT
12	+5V

GTL Bus Frequency Setting - S1,S2

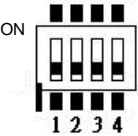

GTL Bus Freq. setting	S2			S1			
	2	3	4	1	2	3	4
\AUTO (Default)	x	x	x	1	0	1	0
CPU 66MHz	0	1	0	1	0	0	1
CPU 100MHz	1	0	0	1	0	1	0
CPU 133MHz	1	0	1	0	1	0	1

Note : Please set the switch to position “ON” when the value is “1”.

System temperature detection – JP1

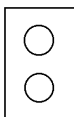

Connect the cable to thermal sensor

Case open detection switch – JP3

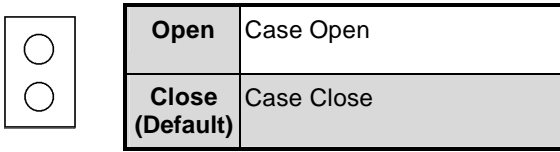

Miscellaneous Connector - CN17

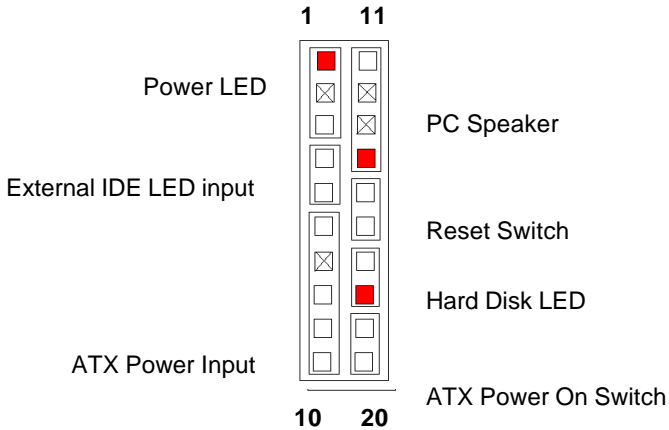

Speaker : Pins 11 - 14

- This connector provides an interface to a speaker for audio tone generation. An 8-ohm speaker is recommended.

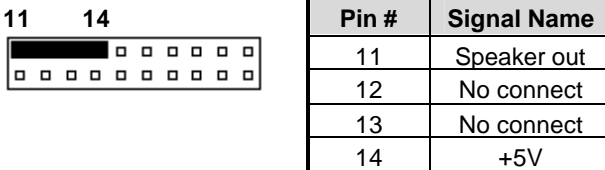

Power LED and External IDE LED input : Pins 11 - 15

- Power LED : The power LED indicates the status of the main power

- External IDE LED input : The external IDE LED input indicates the status of the external IDE channel active signal which is a OR count function with SBC's IDE status. Please connect it with the ACT-pin of external IDE/SCSI card (Ex. mPCI-8219); please reference with the **"Hard Disk LED Connector : Pins 17 and 18"** session as below.

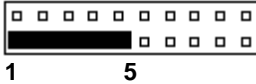

Pin #	Signal Name
1	+5V
2	No connect
3	Power LED#
4	EXT_IDE_ACT
5	Ground

ATX Power ON Switch : Pins19 and 20

- This 2-pin connector is an "ATX Power Supply On/Off Switch" on the system that connects to the power switch on the case. When pressed, the power switch will force the system to power on. When pressed again, it will force the system to power off.

19 20



Reset Switch : Pins 15 and 16

- The reset switch allows the user to reset the system without turning the main power switch off and then on again. Orientation is not required when making a connection to this header.

15 16



Hard Disk LED Connector : Pins 17 and 18

- This connector connects to the hard drive activity LED on control panel. This LED will flash when the HDD is being accessed.
- Hard disk LED = on board hard disk activity OR external IDE LED activity

17 18



Pin #	Signal Name
17	HDD LED#
18	+5V

ATX Power Input : Pins 6 -10

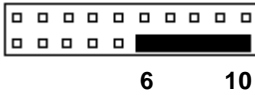

Pin #	Signal Name
6	Ground
7	Ground
8	PowerOn#
9	+5VSB
10	+5VSB

MiniPCI Connector – CN13

This connector is following the MiniPCI Type III standard which is designed for the most of laptop computer. This connector is design for most of application such as SCSI, LAN, VPN or others. Please contact with ADLINK’s reseller for more detail information.

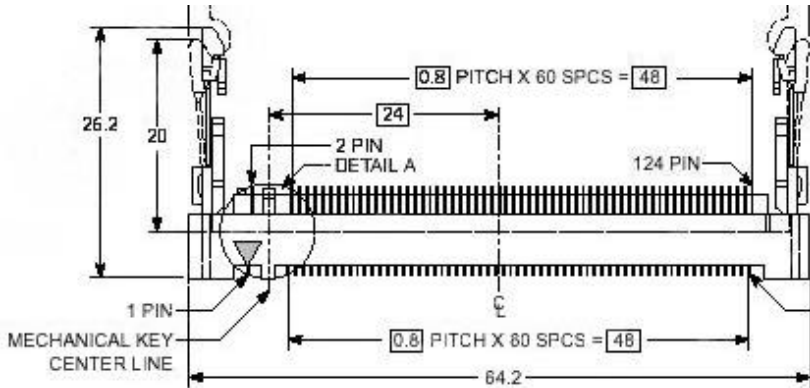

3

Watchdog Programming

EBC-2000 implements a watchdog timer embedded in the 83977EF. The function of the watchdog timer is to reset the system automatically. It contains a one-second/minute resolution down counter, CRF2 of logical device 8, and two Watchdog control registers, WDT_CTRL0 and WDT_CTRL1 of logical device 8. We can use compatible PNP protocol to access configuration registers for setting up watchdog timer configuration.

To program configuration registers, the following configuration sequence must be followed:

1. Enter the extended function mode by writing 87h to the location 370h twice.
2. Configure the configuration registers.
3. Exit the extended function mode by writing 0AAh to the location 370h.

The following example is written in Intel 8086 assembly language. It will reset the system in 15 seconds. We can use both keyboard interrupt and mouse interrupt to cause the watchdog to reload and start to count down from the value of CRF2.

Customer can refer the sample code in X:\CHIPDRV\WDT\DOS\EBC2000

```
MODEL SMALL
```

```
DATA
```

```
CODE
```

```
STARTUP
```

BEGIN:

```
-----  
;Enter the extended function mode, interruptible double-write  
-----  
MOV DX,370H  
MOV AL,87H  
OUT DX,AL  
OUT DX,AL  
-----  
;Configure logical device 7, configuration register CRE2  
-----  
MOV DX,370H  
MOV AL,07H  
OUT DX,AL ;point to logical Device Number Reg.  
MOV DX,371H  
MOV AL,07H ;select device 7  
OUT DX,AL  
  
MOV DX,370H  
MOV AL,0E2H ;device 7, CRE2  
OUT DX,AL  
MOV DX,371H  
MOV AL,0AH ;Watch Dog Timer Output  
OUT DX,AL  
  
MOV DX,370H  
MOV AL,2AH ;CR2A  
OUT DX,AL  
MOV DX,371H  
MOV AL,80H ;bit7=0 -> KBRST, bit7=1 -> GP12  
OUT DX,AL  
  
MOV DX,370H  
MOV AL,07H  
OUT DX,AL  
MOV DX,371H  
MOV AL,08H ;select device 8  
OUT DX,AL  
  
MOV DX,370H
```

```
MOV AL,0F3H ;device 8, CRF3
OUT DX,AL
MOV DX,371H
MOV AL,06H ;Watch Dog Timer is reset upon a
OUT DX,AL ;Mouse & Keyboard interrupt
```

```
MOV DX,370H
MOV AL,07H
OUT DX,AL
MOV DX,371H
MOV AL,08H
OUT DX,AL
```

```
MOV DX,370H
MOV AL,0F4H ;CRF4
OUT DX,AL
MOV DX,371H
MOV AL,40H ;bit6 =1 -> counter counts in seconds
OUT DX,AL ;bit6 =0 -> counter counts in minutes
MOV DX,370H
MOV AL,07H
OUT DX,AL
MOV DX,371H
MOV AL,08H
OUT DX,AL
```

```
MOV DX,370H
MOV AL,0F2H ;CRF2
OUT DX,AL
MOV DX,371H
MOV AL,0FH ;Time-out occurs after the value of CRF2
OUT DX,AL ;range 1~255, 00 -> disable Time-out
```

```
;-----
;Exit extended function mode
;-----
```

```
MOV DX,370H
MOV AL,0AAH
OUT DX,AL
```

```
EXIT
END
```

3.1 Disk On Chip Address

The use of DOC is selectable in BIOS configuration menu. It can be set to Enabled or Disabled. The default setting is Disabled when shipping out. Please referencing the BIOS manual for detail information.

4

VIA VT82C694T Chipset Service Pack (VIA 4 In 1) Installation

VIA 4 In 1 driver includes four system drivers to improve the performance and maintain the stability of systems using VIA chipsets. These four drivers are: VIA Registry (INF) Driver, VIA AGP VxD driver, VIA ATAPI Vendor Support Driver and VIA PCI IRQ Miniport Driver. The 4in1 drivers automatically detect your operating system and will install only what is necessary.

For your information:

VIA IDE Bus Master Driver : For Windows NT users, the VIA IDE Bus Mastering driver is the only driver to be installed in your system.

VIA Registry (INF) Driver will be installed. The driver will enable the VIA Power Management function.

VIA AGP VxD Driver is to be installed. VIAGART.VXD will provide service routines to your VGA driver and interface directly to hardware, providing fast graphical access.

The IDE Filter driver enables the performance enhancing bus mastering functions on ATA-capable Hard Disk Drives and ensures IDE device compatibility. (Also known as the ATAPI Vendor Support Driver)

VIA PCI IRQ Miniport Driver is to be installed under Windows 98 only. It sets the system's PCI IRQ routing sequence.

Installing VIA VT82C694T Chipset Service Pack (VIA 4 In 1)

This subsection describes how to install the VIA VT82C694T Chipset Service Pack (VIA 4 In 1) on a system where Windows 98/NT/2000 is installed.

Note: Record the location of the Windows 98/NT/2000 directory before installing the driver.

1. Check the System Requirements. Windows /98/NT/2000 must be fully installed and running on the system prior to running this software.
2. Close any running applications.
3. In **X:\CHIPDRV\Chipset\VIA_Chip** and then Run SETUP.EXE.
4. Bypass the Welcome dialog by clicking **Next**.
5. This is the readme file, which contains similar information to this installation guide. Click **Yes** to continue.
6. keep the default setup and click **Next** on Setup Components, then install the programs you check.
7. The 4in1 drivers will automatically detect what drivers you need and will tick or check the boxes corresponding to the necessary drivers. It is recommended that you leave these boxes as they appear, unless you are an advanced user. Click **Next**.
8. You will then be taken through each of the ticked drivers one by one.

You may be presented with a Window showing an option:

ATAPI Vendor Support Driver - install and uninstall options. Check the install option (unless you are running the 4in1 driver set up because you have been specifically advised to uninstall this driver).

You may be presented with a Window showing an option:

Check to enable DMA mode

Check this box if your hardware supports DMA. Most new hard drives and CD-ROMs do. Check your hardware manual if you are unsure.

You may be presented with a Window that reads:

Set up Program will install/uninstall AGP driver for you

(Three options)

Install VIA AGP VXD in standard mode

Install VIA AGP VXD in turbo mode

Uninstall VIA AGP VXD

Check turbo mode for optimal performance. If you experience problems and you find our AGP card cannot handle turbo mode, go back and reinstall it in standard mode.

9. Click **Next** for each driver installation, unless you are an experienced user.
10. Your system will then show a progress bar as the drivers are installed.
11. You will be presented with a window that reads:

Set up has finished copying files to your computer. Before you can use the program you must restart Windows or your computer. Yes I want to restart my computer now (ticked by default). Remove any disks from your drivers and then click "Finish" to complete the Set up.
12. Your computer will restart itself and the installation process is complete.

5

LAN Driver Installation

This chapter describes LAN driver installation for the onboard Ethernet controller **Intel 82559**. The relative drivers are under the following ADLINK CD directory: **X:\CHIPDRV\LAN\100pdisk**, where X: is the location of the CD-ROM drive.

5.1 Software and Drivers Support

The 82559 drivers support the following OS or platforms:

Windows 98, Windows 95, Windows 2000, Windows NT

All the above drivers are included in the ADLINK CD. In the following section, we will describe the driver installation for Windows 98, Windows 2000, and Windows NT. For the driver installation of the other OS, please refer the readme file inside the CD.

5.2 Driver Installation on Windows 2000

The Windows 2000 may install the LAN driver. We recommend you to manually installed the most updated LAN driver, which shipped with ADLINK CD to guarantee the compatibility. After installing the Windows 2000, please update the new drivers by the following procedures.

1. Boot Windows 2000, Click **Start**. Select **Settings** then double-click the **Control Panel**.
2. Double-click **System** icon, click **Hardware** tab, click **Device Manager** button.
3. Double-click **Network Adapters** entry, Double-click the **Intel 8255x- based PCI Ethernet Adapter (10/100)** entry.
4. Click **Driver** tab, then click **Update Driver...** button.
5. An Upgrade Device Driver Wizard windows, click **Next>**.
6. Select **Display a list of ...** and click **Next>**. The next window may show a list of hardware models.
7. Insert the CD and click **Have Disk**.
8. Browse the 8255P driver in the following path: **X:\CHIPDRVLAN\100pdisk**, highlight **oemsetup.inf**, click **Open**, then click **OK**.
9. Highlight the model: **Intel 8255x- based PCI Ethernet Adapter (10/100)**, then click **NEXT>**. An Update Driver Warning window may pop up, click **Yes** to continue.
10. Click **NEXT>** button, then the Wizard summary window appears.
11. Click **Finish** button, then click **CLOSE** button.

5.3 Driver Installation on Windows 98

The Windows 98 will install the LAN driver automatically. We recommend you to manually updated the LAN, which on the ADLINK CD to guarantee the compatibility. After installing Windows 98, please update the new drivers by the following procedures.

1. Boot Windows 98, Click **Start**. Select **Settings** then double-click the **Control Panel**.
2. Double-click on the **System** icon, click on the **Device Manager** tab.
3. Double-click on the **Network Adapters** entry,select the Intel **8255x-based PCI Ethernet Adapter (10/100)** entry. Click the **Properties** button.
4. Click on the **Driver** button, then click **Update Driver...** button.
5. Update Device Driver Wizard starts, click **NEXT**.
6. Select **Display a list of ...** and click **NEXT**. The next window allows the user to specify a specific path. Insert the CD and click **Have Disk**.
7. **Browse** the 82559 driver in the following path: **X:\CHIPDRV\LAN\100disk**, highlight **Oemsetup.inf**, click **OK**. The Update Wizard displays the message that it has found the driver. Click **OK** again to update the driver. Note: Windows 98 may ask you to insert the original Windows 98 CD to install the LAN protocols.
8. Click **NEXT** button, then the Wizard summary window appears.
9. Click **Finish** button, then restart the computer to active the new driver.

5.4 Driver Installation on Windows NT

Windows NT may ask to install a LAN driver from its own library of drivers. We recommend you to manually update the LAN, which on the ADLINK CD to guarantee the compatibility. After installing Windows 98, please update the new driver by the following procedures.

1. From the **Control Panel**, double-click the **Network** icon, a Network Configuration window pop up, click **Yes**.
2. In Network Setup Wizard, click **Next>**, click **Select From List...** button.
3. Insert LAN driver floppy diskette into A drive and click **Have Disk**.
4. In the dialog box of Insert Disk window, type in **X:\CHIPDRV\LAN\100pdisk**, Click **OK**.
5. A Select OEM Option window pop up, click **OK**, then click **Next>**.
6. Select necessary Network Protocols, click **Next>**.
7. Select necessary Network Services, click **Next>**.
8. Click **Next>** until Window NT Setup dialog box pop up. Type in **X:\V386** in the dialog box, then insert the original Windows NT CD, click **Continue**.
9. Then click **OK** until the setup completed.

SMBus EEPROM Access library for EBC-2000

EBC-2000 Designed a 2KB EEPROM space for programmer's private data such as security data, software protection and so on, ADLINK provided the programming library for programmer integrated into application programs. The sample code is written by C language and programmer can modify to fit different C compiler.

The SMBus EEPROM is implemented to saved the user's information, such as Vender ID, Module Name.....etc. It can be read/wrote through SMBus. In this readme.txt, we describes how to test EEPROM and how to use the library call under DOS mode.

How to test the SMBus EEPROM ?

1. For MSDOS, Windows 95 or 98

Open a DOS command prompt and execute the following command.

```
tsmbus
```

```
/* This program will read/write two patterns(0x55,0xaa) to test SMBus EEPROM. */
```

```
/*-----*/
```

For the wide use purpose, we provide a sub function for the programmer to implement their software. The sub function's format is as follows:

```
I2CEEPROM_READ(int Byte_Index)
```

```
Byte_Index:0 ~ FFH
```

```
I2CEEPROM_WRITE(int Byte_Index,int Write_Data);
```

```
Byte_Index:0 ~ FFH
```

```
Write_Data:0 ~ FFH
```

```
int Check_SMBus_Busy()
```

```
Return value is 1 ---> SMBus Busy
```

0----> SMBus Ready

/* Check_SMBus_Busy() must exits in I2CEEPROM_READ & I2CEEPROM_WRITE to ensure the data correction of SMBus.

How to use sub function?

For MSDOS, Windows 95 or 98

Make a project program with vsmbus.cpp under Turbo C/C++.

Otherwise, the programmer can transfer the sub function to any format that want to use for their software.

Product Warranty/Service

ADLINK warrants that equipment furnished will be free from defects in material and workmanship for a period of one year from the date of shipment. during the warranty period, we shall, at our option, either repair or replace any product that proves to be defective under normal operation.

This warranty shall not apply to equipment that has been previously repaired or altered outside our plant in any way as to, in the judgment of the manufacturer, affect its reliability. Nor will it apply if the equipment has been used in a manner exceeding its specifications or if the serial number has been removed.

ADLINK does not assume any liability for consequential damages as a result from our product uses, and in any event our liability shall not exceed the original selling price of the equipment. The remedies provided herein are the customer's sole and exclusive remedies. In no event shall ADLINK be liable for direct, indirect, special or consequential damages whether based on contract of any other legal theory.

The equipment must be returned postage-prepaid. Package it securely and insure it. You will be charged for parts and labor if the warranty period is expired or the product is proves to be misuse, abuse or unauthorized repair or modification.