

HPWR104HR

High efficiency PC/104 power supply module

User's Manual

Hardware Revision 1.2-1.3

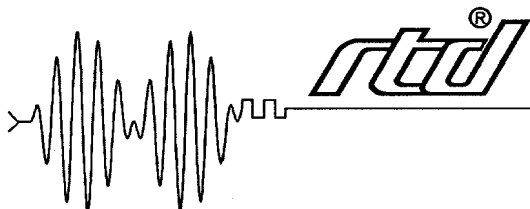

Real Time Devices, Inc.

"Accessing the Analog World"®

HPWR104HR

Power supply module

User's Manual

REAL TIME DEVICES FINLAND OY
LEPOLANTIE 14
FIN-00660 HELSINKI
FINLAND

Phone: (+358) 9 346 4538
FAX: (+358) 9 346 4539

E-Mail
sales@rtdfinland.fi

Website
www.rtdfinland.fi

Revision History

24/06/1999	Release 1.0
10/07/2001	Name of company and format Release 1.3 hardware release

IMPORTANT

Although the information contained herein has been carefully verified, RTD Finland Oy assumes no responsibility for any errors that may occur, for any damage to property or persons resulting from improper use of this manual or from the related software. RTD Finland Oy also reserves the right to alter the contents of this manual, as well as features and specifications of this product at any time, without prior notice.

Notice: We have attempted to verify all information in this manual as of the publication date. Information in this manual may change without prior notice from RTD Finland Oy.

Published by
Real Time Devices Finland Oy
Lepolantie 14
FIN-00660 Helsinki
Finland

Copyright 1999-2001 Real Time Devices Finland Oy
All rights reserved
Printed in Finland

PC/XT, PC/AT are registered trademarks of IBM Corporation.
PC/104 is a registered trademark of PC/104 Consortium.
The Real Time Devices Logo is a registered trademark of Real Time Devices.
utilityModule is a trademark of Real Time Devices.
All other trademarks appearing in this document are the property of their respective owners.

Table of Contents

List of illustrations	5
Chapter 1 Introduction	6
Features	6
Power supply unit	6
Board options	6
Mechanical description	7
Connector description	7
What comes with your board	7
Using this manual	7
When you need help	7
Chapter 2 Board installation	8
Board installation	8
External power connections	10
Power inputs and outputs	
Chapter 3 Hardware description	12
Main +5V converter for computer	14
Secondary power outputs +12V, -12V	14
Onboard status LED's	14
Output protection	15
Output power calculations	16
Chapter 4 HPWR104HR Specifications	16
Chapter 5 Warranty	17

List of illustrations

- Fig. 2-1: HPWR104HR powering an RTD PC/104 cpuModule stack
- Fig. 2-2: HPWR104HR power supply power connections
- Fig. 3-1: HPWR104HR Block diagram

Chapter 1 INTRODUCTION

This user's manual describes the operation of the HPWR104HR power supply unit for automotive and industrial applications.

Features

Some of the key features of the HPWR104HR include:

- Wide input voltage range 8-30V DC
- 75W output power guaranteed **with adequate cooling**, minimum of 90% efficiency
- Outputs continuous short circuit protected
- Remote ON/OFF operation
- Power output options include:

HPWR104HR-1	+5V
HPWR104HR-2	+5V, +12V, -12V
- Two status LED's
- Standard floppy power output connector (J12)
- Fully PC/104 compliant
- **Operating temperature -40 to +85 C**

The following paragraphs briefly describe the major features of the HPWR104HR. A more detailed discussion is included in Chapter 3 (Hardware description) The board installation is described in Chapter 2 (Board Installation).

Power supply units

The HPWR104HR power supply unit offers a complete reliable power subsystem for your sophisticated computer and peripherals. To improve reliability in noisy environments, the HPWR104HR is designed using protection devices against over voltages, noise spikes and reverse input voltage. The output current of the +5V converter is limited to 15A. This enables reliable system operation in distributed industrial installations.

The main +5V computer power supply is designed using a high efficiency switching regulator module providing high output current (15A) with a high efficiency (90%) under all conditions. The secondary peripheral power supplies are designed using +12V and -12V "Boost" converters. Low component count and extensive use of SMD technology ensures low weight and reliable operation.

The HPWR104HR can be "switched off" from a remote source. If this switch (jumper) is closed the power supply will become inactive while still powered.

Board options

The HPWR104HR is available in two main output configurations as set out below:

- | | | |
|----------|--------------------|----------------------------|
| Option 1 | HPWR104HR-1 | +5V output (only upon) |
| Option 2 | HPWR104HR-2 | +5V, +12V and -12V outputs |

Mechanical description

The HPWR104HR is designed on a PC/104 form factor. An easy mechanical interface to both PC/104 and EBX systems can be achieved. Stack your HPWR104HR directly on a PC/104 compliant computer using the onboard mounting holes. Care must be taken to ensure adequate heat dissipation from the onboard heat sink in high output power installations.

Connector description

The power connections are made using "cable plug" type terminal blocks. This enables removing connections from the board without opening the cables from the terminal blocks. A 4-pole "floppy type" connector is also available for easy wiring to PC peripherals. The IDAN-HPWR104HR boards always feature screw terminal blocks for inter-frame wiring.

What comes with your board

Your HPWR104HRHR package contains the following items:

- HPWR104HR board with mating connectors for the power connections
- User's manual

If any item is missing or damaged, please call Real Time Devices Finland customer service department at the following number: (+358) 9 346 4538.

Using this manual

This manual is intended to help you install your new HPWR104HR module and get it working quickly, while also providing enough detail about the board and its functions so that you can enjoy maximum use of its features even in the most demanding applications.

When you need help

This manual and all the example programs will provide you with enough information to fully utilize all the features on this board. If you have any problems installing or using this board, contact our Technical Support Department (+358) 9 346 4538 during European business hours. Alternatively, send a FAX to (+358) 9 346 4539 or Email to sales@rtdfinland.fi. When sending a FAX or Email request please include the following information: Your company's name and address, your name, your telephone number, and a brief description of the problem.

Chapter 2 **BOARD INSTALLATION**

The HPWR104HR isolated power supply module is very easy to connect to your industrial or automotive control system. Direct interface to PC/104 systems as well as EBX size boards is achieved. This chapter tells you step-by-step how to install your HPWR104HR into your system.

Board installation

Keep your board in its antistatic bag until you are ready to install it to your system! When removing it from the bag, hold the board at the edges and do not touch the components or connectors. Please handle the board in an antistatic environment and use a **grounded** workbench for testing and handling of your hardware. Before installing the board in your computer, check the power cabling. Failure to do so may cause the power supply unit to malfunction or even cause permanent damage.

General installation guidelines:

- Touch the grounded metal housing of your computer to discharge any antistatic buildup and then remove the board from its antistatic bag.
- Hold the board by the edges and install it in an enclosure or place it on the table on an antistatic surface.
- Install your board in your system, and wire the power supply correctly.
- Failure to do so may cause the power supply unit to malfunction or even cause permanent damage to the device.
- Check all wiring connections once and then once more again.
- Check the input power to the board is in the range of 8 to 30V DC
- Apply power to your HPWR104HR, and make sure the diagnostic LED's indicate correct operation.

Installation integrated with a PC/104 module stack:

- Secure the four PC/104 installation holes with standoffs.
Connect the board to the power supply using the power interface connectors.

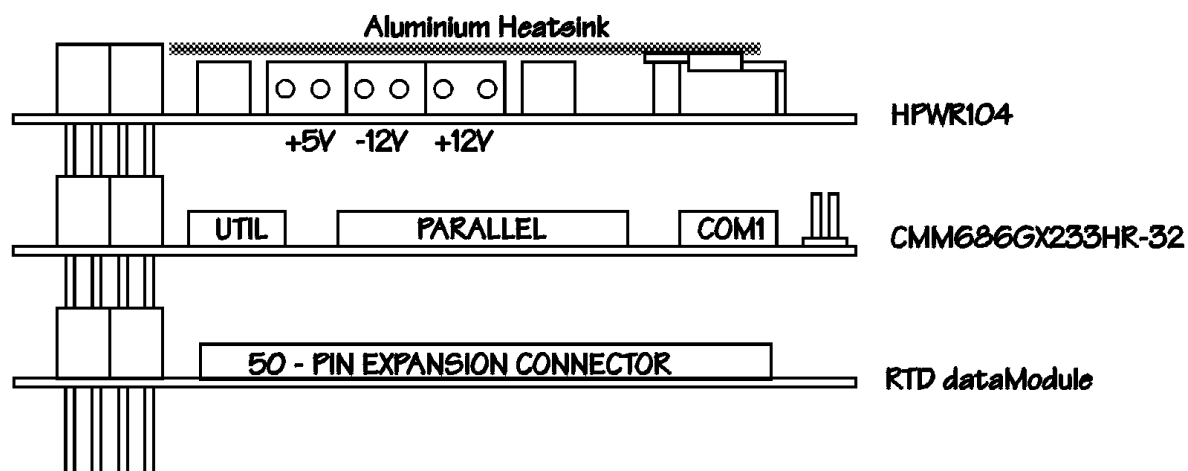

Fig. 2-1: HPWR104HR powering an RTD PC/104 cpuModule stack

Note: For full output power performance, install your HPWR104HR at the top of your PC/104 system and make sure adequate cooling is provided. You may increase airflow with the EFAN104 fan module available from Real Time Devices.

External power connections

The illustration 2-2 below indicates the input and output power connections of the HPWR104HR board mounted in its IDAN enclosure frame. This illustration also shows the RTD EMI filter that is required to meet CE compliance to EN55022-A. Using IDAN systems the power devices are directly heat sunk to the frame this will give full rated output performance over the complete temperature range of -40 to +85 C.

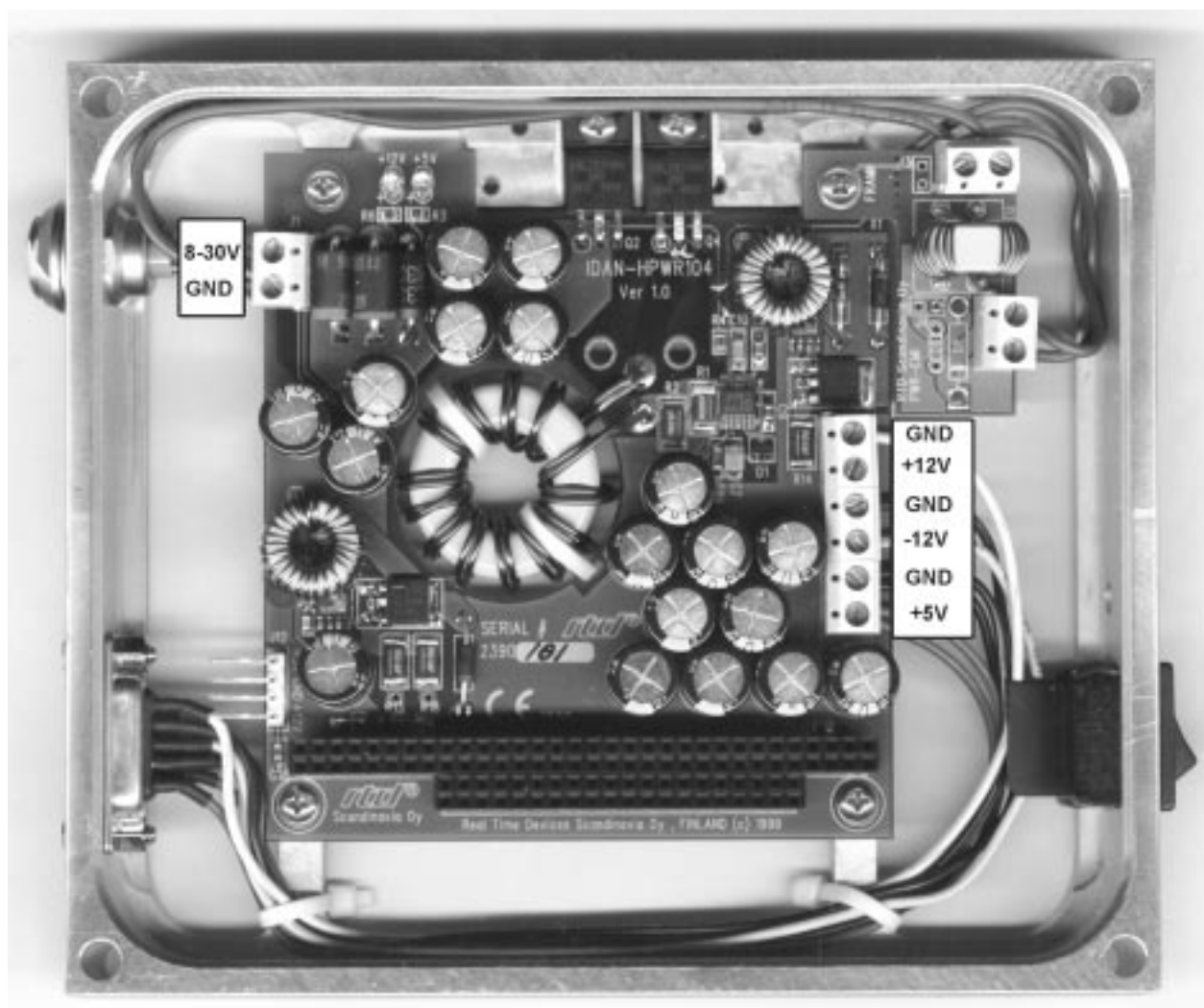

Fig. 2-2 HPWR104HR power supply power connections

Connector descriptions:

- **J1:** Raw input power to the HPWR104HR. Input voltage range is 8-30V DC. Overvoltage protected with transient absorber with cutoff at 33V DC.

Note: The module input power may be up to 85 W (11A), this will require a cable wire diameter of 2 to 3 sq. mm. Make sure this input wire is kept as short as possible to reduce voltage drops.

- **J2:** +5V Output of the main DC/DC power supply
- **J11:** -12V Output (Only on -2 versions of HPWR104HR)
- **J4:** +12V Output (Only on -2 versions of HPWR104HR)
- **J12:** Floppy power output connector , +5V and +12V outputs:
Pin #1 +5V, #2,3 GND and pin #4 +12V
- **X1:** Remote ON/OFF , close this jumper to disable the HPWR104HR
(Not shown in this figure)

The output voltages are also indicated on the silk-screen on the solder side of the module under the terminal blocks. Check these before making any external power connections. The input of the HPWR104HR is protected against reverse voltages, but will not withstand long term overvoltage. The transient absorbers will clip all fast disturbance and noise on the input, but may overheat if continuous overvoltage is present.

Chapter 3 - **HARDWARE DESCRIPTION**

This chapter describes the major features of the HPWR104HR, which are the following:

- The main +5V converter for the computer and PC/104 bus
- The secondary power output converters +12V and -12V for peripheral devices
- Onboard status LED's
- Overload protection
- Output power calculations

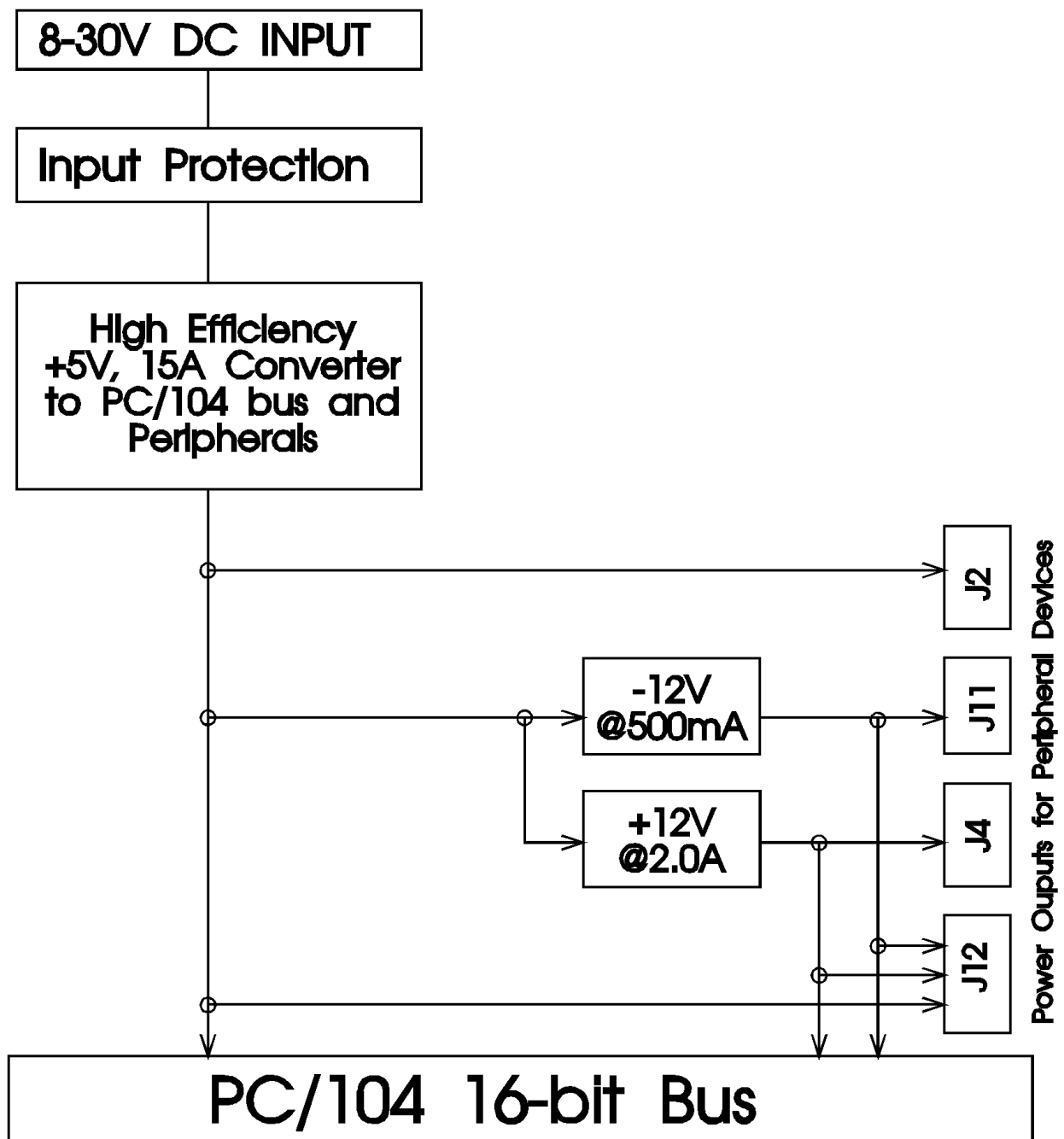

Fig. 3-1 Block diagram of the HPWR104HR-2

Main +5V converter for computer

The main +5V output is implemented with a synchronous, switch-mode DC-DC converter design. The output current of this unit is 15A. This converter has excellent dynamic and transient response capabilities making it an ideal high-speed computer power supply. The output current is internally limited against over current and short circuit faults at 17A.

The input of this converter is protected with a 33V fast transient absorber diode and low loss forward schottky diodes. These devices are necessary to protect the input in automotive and industrial installations against fast overvoltage spikes and reverse voltage transients. These situations exist in vehicle systems that use for example electrically controlled hydraulic or pneumatic inductive valves and solenoids.

The main +5V converter feeds the PC/104 AT bus +5V pins with power. This power can also be taken from the board from an external terminal block J2. (See previous section for the location of terminal block J2.)

Current Limit

To protect against fault or short-circuit conditions the +5V DC/DC converter module is equipped with a current limiting circuitry to provide continuous overload protection. After reaching the current limit point (typically 10 to 25% over the rated current), the voltage output will range between the rated output and zero depending on the amount of overload. Once the short circuit condition is removed, the output will return to the nominal value without restarting the unit.

Remote On/Off control

Header connector X1 near one of the PC/104 mounting holes is the remote ON/OFF selection switch. Closing this connection will disable the HPWR104HR and place the converter "OFF". In this condition the HPWR104HR will consume minimum power. This signal could be connected to the ignition key of an automobile or machine.

Secondary +12V and -12V converters for peripherals

A 5V to +-12V step up converters with 90% efficiency generates +-12V for peripheral devices such as EL- or TFT- panels, hard drives, motors etc. The +12V output delivers 2,0A of current. +12V power is available from terminal block J4. The -12V power is available from terminal block J1. (See previous section for location of J4/J1.) . The +12V and -12V supplies also power the PC/104 bus.

Onboard status LED's

The HPWR104HR is equipped with 2 indicator LED's. The function of the LED's is described below.

- LED1 - Green. Indicates +5V power converter is alive
- LED2 - Green. Indicates +12V converter is alive

Overload protection

The +5V converter is current limited to 17A. The current limit is higher than the maximum continuous output current to ensure reliable operation near the maximum rated output power. Fast current surges are allowed over the rated 15A continuous current.

The +12V converter is rated to 2A and the -12V converter is rated for 500mA. The +12V converter output is limited to 3A. The -12V converter output is limited to 1A. The outputs of the +12V and -12V converters feature a 13V zener diode to protect your system from external error conditions such as incorrect power connections. These devices will allow short-term error conditions, and are not designed to accept long-term overvoltage or reverse polarity.

Output power calculations

The maximum available power for the +5V computer system can be estimated using the following conservative formula:

(The output of the main converter is 15A)

$$\begin{aligned} I_1 &= \text{(+12V output current)} \\ I_2 &= \text{(-12V output current)} \\ I_{\text{bus}} &= \text{+5V to bus} \\ 15A &= (I_1/0.88 + I_2/0.82) * 2.5 + I_{\text{bus}} \end{aligned}$$

Note: Even though the total output power figure of 15A @5V is not exceeded you must remember not to overload an individual output! Care must be taken not to thermally overload the unit. The maximum specified output power may not be available if the ambient temperature rises, and in this case additional heat sinking or additional airflow may be necessary.

The absolute maximum long-term output figures are:

+12V -> 2A
-12V -> 1A
+5V -> 12A

The absolute maximum output figures are:

+12V -> 3A
-12V -> 2A
+5V -> 17A

Chapter 4 HPWR104HR SPECIFICATIONS

Host interface

16-bit data bus with power pins +5V, +-12V connected to power outputs

Power supply specifications

Input voltage range guaranteed	8-30V DC
Input voltage range under light load 25%	6-30V DC
Output Power (75W total)	+5V@15A +12V@2,0A -12V@500mA
Efficiency	90%
Output voltage unloaded	+5,15V (max)
Output voltage fully loaded	+4,95V (min@15A)

Connectors

Power connectors	Phoenix Contact Combicon Series "Mini floppy connector"
Host bus (Optionally no bus connector)	AT PC/104 bus

Electromechanical

Operating temperature range	-40 to +85 C
Heat sink temperature (Max)	+85 C
Internal power dissipation	14W (Max)
Heat sink material	Aluminum

CE approval

CE approved in an IDAN installation

Chapter 5 RETURN POLICY AND WARRANTY

Return Policy

If the module requires repair, you may return it to us by following the procedure listed below:

Caution: Failure to follow this return procedure will *almost always* delay repair! Please help us expedite your repair by following this procedure.

- 1) Read the limited warranty, which follows.
- 2) Contact the factory and request a Returned Merchandise Authorization (RMA) number.
- 3) On a sheet of paper, write the name, phone number, and fax number of a technically competent person who can answer questions about the problem.
- 4) On the paper, write a detailed description of the problem with the product. Answer the following questions:
 - Did the product ever work in your application?
 - What other devices were connected to the product?
 - How was power supplied to the product?
 - What features did and did not work?
 - What was being done when the product failed?
 - What were environmental conditions when the product failed?
- 5) Indicate the method we should use to ship the product back to you.
 - We will return warranty repairs by UPS Ground at our expense.
 - Warranty repairs may be returned by a faster service at your expense.
 - Non-warranty repairs will be returned by UPS Ground or the method you select, and will be billed to you.
- 6) Clearly specify the address to which we should return the product when repaired.
- 7) Enclose the paper with the product being returned.
- 8) Carefully package the product to be returned *using anti-static packaging!* We will not be responsible for products damaged in transit for repair.
- 7) Write the RMA number on the outside of the package.
- 8) Ship the package to:

Real Time Devices Finland Oy

Lepolantie 14

FIN-00750 Helsinki

FINLAND

Limited Warranty

Real Time Devices warrants the hardware and software products it manufactures and produces to be free from defects in materials and workmanship for one year following the date of shipment from REAL TIME DEVICES. This warranty is limited to the original purchaser of product and is not transferable.

During the one year warranty period, REAL TIME DEVICES will repair or replace, at its option, any defective products or parts at no additional charge, provided that the product is returned, shipping prepaid, to REAL TIME DEVICES. All replaced parts and products become the property of REAL TIME DEVICES. Before returning any product for repair, customers are required to contact the factory for an RMA number.

THIS LIMITED WARRANTY DOES NOT EXTEND TO ANY PRODUCTS WHICH HAVE BEEN DAMAGED AS A RESULT OF ACCIDENT, MISUSE, ABUSE (such as: use of incorrect input voltages, improper or insufficient ventilation, failure to follow the operating instructions that are provided by REAL TIME DEVICES, "acts of God" or other contingencies beyond the control of REAL TIME DEVICES), OR AS A RESULT OF SERVICE OR MODIFICATION BY ANYONE OTHER THAN REAL TIME DEVICES. EXCEPT AS EXPRESSLY SET FORTH ABOVE, NO OTHER WARRANTIES ARE EXPRESSED OR IMPLIED, INCLUDING, BUT NOT LIMITED TO, ANY IMPLIED WARRANTIES OF MERCHANTABILITY AND FITNESS FOR A PARTICULAR PURPOSE, AND REAL TIME DEVICES EXPRESSLY DISCLAIMS ALL WARRANTIES NOT STATED HEREIN. ALL IMPLIED WARRANTIES, INCLUDING IMPLIED WARRANTIES FOR MERCHANTABILITY AND FITNESS FOR A PARTICULAR PURPOSE, ARE LIMITED TO THE DURATION OF THIS WARRANTY. IN THE EVENT THE PRODUCT IS NOT FREE FROM DEFECTS AS WARRANTED ABOVE, THE PURCHASER'S SOLE REMEDY SHALL BE REPAIR OR REPLACEMENT AS PROVIDED ABOVE. UNDER NO CIRCUMSTANCES WILL REAL TIME DEVICES BE LIABLE TO THE PURCHASER OR ANY USER FOR ANY DAMAGES, INCLUDING ANY INCIDENTAL OR CONSEQUENTIAL DAMAGES, EXPENSES, LOST PROFITS, LOST SAVINGS, OR OTHER DAMAGES ARISING OUT OF THE USE OR INABILITY TO USE THE PRODUCT.

SOME STATES DO NOT ALLOW THE EXCLUSION OR LIMITATION OF INCIDENTAL OR CONSEQUENTIAL DAMAGES FOR CONSUMER PRODUCTS, AND SOME STATES DO NOT ALLOW LIMITATIONS ON HOW LONG AN IMPLIED WARRANTY LASTS, SO THE ABOVE LIMITATIONS OR EXCLUSIONS MAY NOT APPLY TO YOU.

THIS WARRANTY GIVES YOU SPECIFIC LEGAL RIGHTS, AND YOU MAY ALSO HAVE OTHER RIGHTS, WHICH VARY FROM STATE TO STATE.