

NuDAQ[®]

ACL-8113A

12-bit 32 Channels
Isolated Analog Input Card

User's Guide

©Copyright 1995–2000 ADLINK Technology Inc.

All Rights Reserved.

Manual Rev. 2.20: November 7, 2000

The information in this document is subject to change without prior notice in order to improve reliability, design and function and does not represent a commitment on the part of the manufacturer.

In no event will the manufacturer be liable for direct, indirect, special, incidental, or consequential damages arising out of the use or inability to use the product or documentation, even if advised of the possibility of such damages.

This document contains proprietary information protected by copyright. All rights are reserved. No part of this manual may be reproduced by any mechanical, electronic, or other means in any form without prior written permission of the manufacturer.

Trademarks

NuDAQ is registered trademark of ADLINK Technology Inc.,

Other product names mentioned herein are used for identification purposes only and may be trademarks and/or registered trademarks of their respective companies.

Getting service from ADLINK

- ◆ **Customer Satisfaction is always the most important thing for ADLINK Tech Inc. If you need any help or service, please contact us and get it.**

ADLINK Technology Inc.			
Web Site	http://www.adlink.com.tw		
	http://www.adlinktechnology.com		
Sales & Service	service@adlink.com.tw		
Technical	NuDAQ	nudaq@adlink.com.tw	
Support	NuDAM	nudam@adlink.com.tw	
	NuIPC	nuipc@adlink.com.tw	
	NuPRO	nupro@adlink.com.tw	
	Software	sw@adlink.com.tw	
TEL	+886-2-82265877	FAX	+886-2-82265717
Address	9F, No. 166, Jian Yi Road, ChungHo City, Taipei, 235 Taiwan, R.O.C.		

- ◆ **Please inform or FAX us of your detailed information for a prompt, satisfactory and constant service.**

Detailed Company Information			
Company/Organization			
Contact Person			
E-mail Address			
Address			
Country			
TEL		FAX	
Web Site			
Questions			
Product Model			
Environment to Use	<input type="checkbox"/> OS:		
	<input type="checkbox"/> Computer Brand:		
	<input type="checkbox"/> M/B:	<input type="checkbox"/> CPU:	
	<input type="checkbox"/> Chipset:	<input type="checkbox"/> BIOS:	
	<input type="checkbox"/> Video Card:		
	<input type="checkbox"/> Network Interface Card:		
	<input type="checkbox"/> Other:		
Challenge Description			
Suggestions for ADLINK			

Table of Contents

Chapter 1 Introduction	1
1.1 Features	1
1.2 Applications	2
1.3 Specifications.....	2
1.4 Software Support	3
1.4.1 <i>Programming Library</i>	3
1.4.2 <i>LabView Driver</i>	3
Chapter 2 Installation	4
2.1 What You Have	4
2.2 Unpacking	4
2.3 ACL-8113A's Layout.....	5
2.4 Jumper and DIP Switch Description.....	6
2.5 Base Address Setting	6
2.6 Input Range Selection	7
2.7 Connector Pin Assignment.....	9
Chapter 3 Registers Format	10
3.1 I/O Port Address Map	10
3.2 A/D Data Registers	11
3.3 A/D Channel Control Register	11
3.4 A/D Range Control Register	12
Chapter 4 Operation Theorem	14
4.1 A/D Conversion Procedure	14
4.2 A/D Signal Source Control	15
4.3 A/D Trigger Source Control	16
4.4 A/D Data Conversion	17
Chapter 5 C/C++ Library for DOS	19
5.1 Installation	20
5.2 C Language Library	20
5.3 <code>_8113_Initial</code>	21
5.4 <code>_8113_ActCard_Set</code>	22
5.5 <code>_8113_Channel_Select/Deselect</code>	23
5.6 <code>_8113_Gain_Select</code>	24
5.7 <code>_8113_AD_Acquire</code>	26

5.8	_8113_MAD_Acquire	27
Chapter 6 Calibration		28
6.1	What do you need	28
6.2	VR Assignment	28
6.3	Bipolar A/D Adjustment	29
6.4	Uni-polar A/D Adjustment.....	29
Product Warranty/Service		30

How to Use This Guide

This manual is designed to help you use the ACL-8113A. The manual describes how to modify various settings on the ACL-8113A card to meet your requirements. It is divided into seven chapters:

- **Chapter 1**, "Introduction," gives an overview of the product features, applications, and specifications.
- **Chapter 2**, "Installation," describes how to install the ACL-8113A. The layout is shown, the switch setting for base address, and jumpers setting for analog input channel configuration are specified.
- **Chapter 3**, "Registers format" describes the details of register format and structure of the ACL-8113A, this information is very important for the programmers who want to control the hardware by low-level programming.
- **Chapter 4**, "Operation Theorem" describes how to operate the A/D sequence on the ACL-8113A.
- **Chapter 5**, "C/C++ library" describes high-level programming interface in C/C++ language. It helps programmer to control ACL-8113A in high level language style .
- **Chapter 6**, "Calibration," describes how to calibrate the ACL-8113A for accuracy measurement.



Introduction

The ACL-8113A is a 12-bit 32-channel single-ended isolated A/D card with ISA interface. The ACL-8113A is an ideal cost effective solution for applications in industrial measurement and monitoring.

The ACL-8113A is designed to meet high voltage isolation on each analog channel. Isolated input signal design protect the PC and peripherals from damage due to high voltages on the input channels. The on-board signal conditioning circuits help user to attenuate the analog input or provide the holes for I-to-V conversion. In addition, two DC-to-DC converters and software programmable gain on each channel are provided for stability and flexibility.

1.1 Features

The ACL-8113A 32-Channel S.E. Isolated A/D Card provides the following advanced features:

- 32 single-end analog input channels
- Over 2500 VDC Isolation
- On board signal conditioning circuits
- 12-bit successive approximation A/D converter (AD774 or equivalent)
- Bipolar or uni-polar Analog input range
- Software programmable gain control
- Integral DC-to-DC converter for stable input operation
- Compact size - only half-size PCB
- 4-layer PCB with an integral ground plane

1.2 Applications

- Measurement of transducer and sensor data
- Multiple channel measurement
- Waveform acquisition and measurement
- Process monitor
- Vibration and transient analysis
- Signal isolation

1.3 Specifications

The ACL-8113A provides the following specifications:

Analog Input (A/D)

- **Input Channel:** 32 Isolated channels
- **Resolution:** 12-bit
- **Input Range:**
 - 10V Range:**
Bi-polar: $\pm 5V, \pm 2.5V, \pm 1.25V, \pm 0.625V, \pm 0.3125V$
Uni-polar: $0\sim 10V, 0\sim 5V, 0\sim 2.5V, 0\sim 1.25V, 0\sim 0.625V$
 - 20V Range:**
Bi-polar: $\pm 10V, \pm 5V, \pm 2.5V, \pm 1.25V, \pm 0.625V$
Uni-polar: $0\sim 10V, 0\sim 5V, 0\sim 2.5V, 0\sim 1.25V$
 - Over-voltage Protection:** Continuous $\pm 35V$ maximum
- **Converter Type:** Successive approximation
- **Converter:** B.B. AD774 or equivalent
- **Conversion Speed:** 50 KHz maximum
- **Accuracy:** 0.015% of reading ± 1 LSB
- **None-linearity:** ± 1 bit maximum
- **AD conversion trigger Mode:** Software Trigger
- **Data Transfer:** Program Control
- **Input Impedance:** $> 10M\Omega$
- **Temperature coefficient:** 5 ppm typical, 15 ppm maximum

General Specifications

- **Connector:** 37-pin D-type connector
- **Operating Temperature:** 0° C ~ 55° C
- **Storage Temperature:** -20° C ~ 80° C
- **Humidity:** 5 ~ 95%, non-condensing
- **Power Consumption:** +5 V @ 960 mA maximum
- **Dimension:** 160mm(L) X 122mm(W)

1.4 Software Support

1.4.1 Programming Library

For the customers who are writing their own programs, we provide MS-DOS Borland C/C++ and MS C libraries, which are free.

ACLS-DLL2 is the Development Kit for NuDAQ ISA Bus Cards with Analog I/O, windows 3.1/95(98)/NT. ACLS-DLL2 can be used for many programming environments, such as VC++, VB, Delphi. ACLS-DLL2 is included in the ADLINK CD. It need license.

1.4.2 LabView Driver

The ACLS-LVIEW includes the ACL-8316/8312's VIs, which is used to interface with NI's LabView software package. The ACLS-LVIEW supports Windows-95(98)/NT. ACLS-LVIEW is included in the ADLINK CD. It need license.

2

Installation

This chapter describes how to install the ACL-8113A. At first, the contents in the package and unpacking information that you should be careful are described. The jumpers and switches setting for the ACL-8113A's base address and input range selection are also specified.

2.1 What You Have

In addition to this *User's Manual*, the package includes the following items:

- ACL-8113A 32-CH S.E. Isolated A/D card
- ADLINK CD

If any of these items is missing or damaged, contact the dealer from whom you purchased the product. Save the shipping materials and carton in case you want to ship or store the product in the future.

2.2 Unpacking

Your ACL-8113A card contains sensitive electronic components that can be easily damaged by static electricity.

The card should be done on a grounded anti-static mat. The operator should be wearing an anti-static wristband, grounded at the same point as the anti-static mat.

Inspect the card module carton for obvious damage. Shipping and handling may cause damage to your module. Be sure there are no shipping and handling damages on the module before processing.

After opening the card module carton, extract the system module and place it only on a grounded anti-static surface component side up.

Again inspect the module for damage. Press down on all the socketed IC's to make sure that they are properly seated. Do this only with the module place on a firm flat surface.

Note: DO NOT APPLY POWER TO THE CARD IF IT HAS BEEN DAMAGED.

You are now ready to install your **ACL-8113A**.

2.3 ACL-8113A's Layout

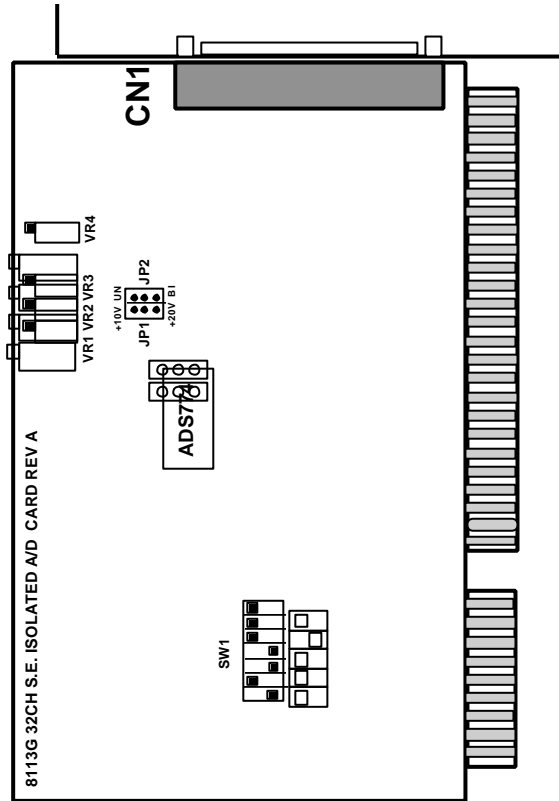

2.4 Jumper and DIP Switch Description

You can change the ACL-8113A's channels and base address by setting jumpers and DIP switches on the card. The card's jumpers and switches are preset at the factory. Under normal circumstances, you should not need to change the jumper settings.

A jumper switch is closed (sometimes referred to as "shorted" with the plastic cap inserted over two pins of the jumper). A jumper is open with the plastic cap inserted over one or no pin(s) of the jumper.

2.5 Base Address Setting

The ACL-8113A requires 16 consecutive address locations in I/O address space. The base address of the ACL-8113A is restricted by the following conditions.

- 1.The base address must be within the range 000hex to 3F0hex.
- 2.The base address should not conflict with any reserved I/O address.

The ACL-8113A's I/O port base address is selectable by an 5 position DIP switch SW1. The address setting for I/O port from Hex 000 to Hex 3F0 is described in Table 2.1. The factory default base address is **Hex 220** and its corresponding SW1 setting is illustrated as Figure 2.2.

SW1 : Base Address = Hex 220

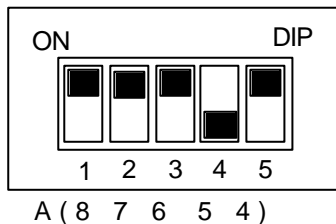

Figure 2.2 Base Address Default Setting

I/O port Address (hex)	1 A9	2 A8	3 A7	4 A6	5 A5	6 A4
000-00F	ON (0)	ON (0)	ON (0)	ON (0)	ON (0)	ON (0)
010-01F	ON (0)	ON (0)	ON (0)	ON (0)	ON (0)	OFF (1)
:						
210-21F	OFF (1)	ON (0)	ON (0)	ON (0)	ON (0)	OFF (1)
(*) 220-22F	OFF (1)	ON (0)	ON (0)	ON (0)	OFF (1)	ON (0)
230-23F	OFF (1)	ON (0)	ON (0)	ON (0)	ON (0)	OFF (1)
:	:	:	:	:	:	:
3F0-3FF	OFF (1)	OFF (1)	OFF (1)	OFF (1)	OFF (1)	OFF (1)

(*): default setting

ON = 0; OFF = 1.

A9, ..., A4 are corresponding to PC Bus address lines

A3, A2, A1 and A0 are fixed by 0 with hardware

How to define the base address for the ACL-8113A?





The DIP1 to DIP6 in the switch SW1 are one to one corresponding to the PC bus address line A8 to A4. A9 is always 1 and A0~A3 are always 0. If you want to change the base address, you can only change the values of A8 to A4 (the shadow area of below table). The following table is an example, which shows you how to define the base address as **Hex 220**

Base Address: **Hex 220**

2		2				0			
1	0	0	0	1	0	0	0	0	0
A9	A8	A7	A6	A5	A4	A3	A2	A1	A0

2.6 Input Range Selection

The ACL-8113A's analog input voltage ranges can be selected through the jumpers **JP1** and **JP2**. The JP1 is used to choose the Voltage range **10V or 20V**, and JP2 is used to select **Bipolar input or Unipolar input**. The combinations of JP1, JP2 and their corresponding input voltage ranges are listed on the table of next page.

JP1	+10V (Default)	+20V
+10V and +20V Input Range Setting	+10V  +20V	+10V  +20V
JP2	Unipolar	Bipolar (Default)
Unipolar and Bipolar Setting	UN  BI	UN  BI

Summary:









AI Range & Modes	JP1	JP2	Gain: Input Voltage Range
Input Range 10V & Bipolar Mode (Default)	10V  20V	UN  BI	X1: -5V ~ +5V X2: -2.5V ~ +2.5V X4: -1.25V ~ +1.25V X8: -0.625V ~ +0.625V X16: -0.3125V ~ +0.3125V
Input Range 10V & Uni-polar Mode	10V  20V	UN  BI	X1: 0V ~ 10V X2: 0V ~ 5V X4: 0V ~ 2.5V X8: 0V ~ 1.25V X16: 0V ~ 0.625V
10V  20V	UN  BI		X1: -10V ~ 10V X2: -5V ~ +5V X4: -2.5V ~ +2.5V X8: -1.25V ~ +1.25V X16: -0.625V ~ +0.625V
10V  20V	UN  BI		X1: Not Used X2: 0V ~ 10V X4: 0V ~ 5V X8: 0V ~ 2.5V X16: 0V ~ 1.25V

Table 2.2 Analog Input Range Summary

2.7 Connector Pin Assignment

The ACL-8113A comes equipped with one DB-37 female connector on the card's mounting bracket. The pin assignment of 37-pin female connector is illustrated in Figure 2.3 as following.

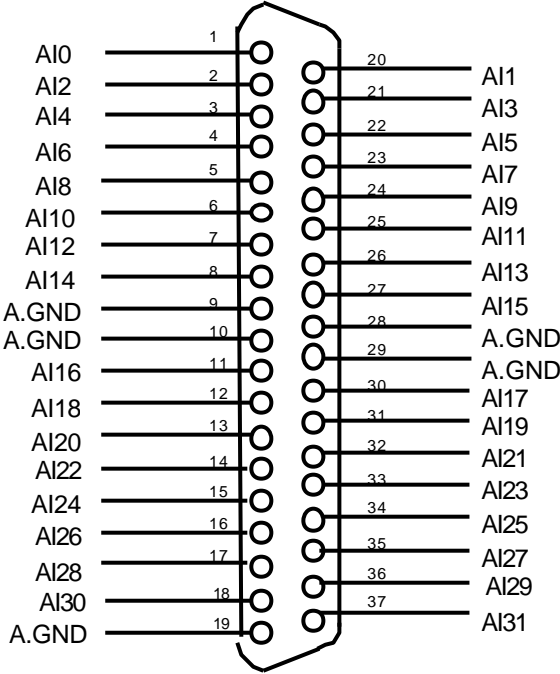

Figure 2.3 Pin Assignment of DB-37 female connector

Legend:

AI n : Analog Input CH n

A.GND: Analog Ground

3

Registers Format

The detailed description of the register format and structure of the ACL-8113A are specified in this chapter. This information is quite useful for the programmers who wish to handle the ACL-8113A card by low-level programming.

In addition, the low level programming syntax is introduced. This information can help the beginners to operate the ACL-8113A in the shortest learning time.

3.1 I/O Port Address Map

The ACL-8113A requires 16 consecutive addresses in the PC I/O address space. The following table shows the location of each register and driver relative to the base address, and its description.

Location	READ	WRITE
Base + 0	Not Used	Not Used
Base + 1	Not Used	Not Used
Base + 2	Not Used	Not Used
Base + 3	Not Used	Not Used
Base + 4	A/D low byte	Not Used
Base + 5	A/D high byte	Not Used
Base + 6	Not Used	Not Used
Base + 7	Not Used	Not Used
Base + 8	Not Used	Not Used
Base + 9	Not Used	Gain Control
Base + 10	Not Used	AD Channel Control
Base + 11	Not Used	Not Used
Base + 12	Not Used	Software A/D trigger
Base + 13	Not Used	Not Used
Base + 14	Not Used	Not Used
Base + 15	Not Used	Not Used

3.2 A/D Data Registers

The ACL-8113A provides 32 single-ended A/D input channels, the converted digital data will store in the A/D data registers after the conversion. The 12 bits A/D data is put into two 8 bits registers. The low byte data (8 LSBs) are put in address *BASE+4* and the high byte data (4 MSBs) are put in address *BASE+5*. A *DRDY* bit is used to indicate the status of A/D conversion. *DRDY* goes to “low” means A/D conversion is completed.

Address: *BASE + 4* and *BASE + 5*

Attribute: read only

Data Format:

Bit	7	6	5	4	3	2	1	0
<i>BASE+4</i>	AD7	AD6	AD5	AD4	AD3	AD2	AD1	AD0
<i>BASE+5</i>	0	0	0	DRDY	AD11	AD10	AD9	AD8

AD11 .. AD0: Analog to digital data. AD11 is the Most Significant Bit (MSB). AD0 is the Least Significant Bit(LSB).

DRDY: Data Ready Signal.

1: A/D data is not ready

0: A/D conversion is completed.

It will be set to 1, when reading the low byte.

3.3 A/D Channel Control Register

This register is used to control the A/D channels to be converted. It's a write only register. When the channel number is written to the register, the multiplexer switches to the new channel and await for conversion.

Address: *BASE + 10*

Attribute: write only

Data Format:

Bit	7	6	5	4	3	2	1	0
<i>BASE+10</i>	X	X	X	CL4	CL3	CL2	CL1	CL0

CLn: multiplexer channel number.

CL4 is MSB, and CL0 is LSB.

The combinations of CH4 ~ CH0 and their corresponding channel number is listed in the table 3.2 below.

Channel No.	CH4	CH3	CH2	CH1	CH0
0	0	0	0	0	0
1	0	0	0	0	1
2	0	0	0	1	0
3	0	0	0	1	1
:					
30	1	1	1	1	0
31	1	1	1	1	1

Table 3.2 Channel Multiplexing

3.4 A/D Range Control Register

The A/D range register is used to adjust the analog input ranges for A/D channels. Two factor will effect the input range: Gain and Bipolar/Unipolar. Both of these issues can be controlled by this register. The Table 4.2 shows the relationship between the register data and the A/D input range.

Address: BASE + 9

Attribute: write only

Data Format:

Bit	7	6	5	4	3	2	1	0
	X	X	X	X	X	G2	G1	G0

The relationship between input voltage range, maximum input voltage and gain is specified as the equation:

$$\text{Analog Input Range} = \text{Maximum Input Voltage} / \text{Gain}$$

The possible gains and their corresponding input ranges are listed in the following table:

Analog Input Range Setting by JP1 & JP2	G2	G1	G0	GAIN	Input Range
	0	0	0	X1	$\pm 5\text{ V}$
10V & Bipolar	0	0	1	X2	$\pm 2.5\text{ V}$
	0	1	0	X4	$\pm 1.25\text{ V}$
	0	1	1	X8	$\pm 0.625\text{ V}$
	1	0	0	X16	$\pm 0.3125\text{ V}$
	0	0	0	X1	0 ~ +10 V
10V & Uni-polar	0	0	1	X2	0 ~ +5 V
	0	1	0	X4	0 ~ +2.5 V
	0	1	1	X8	0 ~ +1.25 V
	1	0	0	X16	0 ~ +0.625 V
	0	0	0	X1	$\pm 10\text{ V}$
20V & Bipolar	0	0	1	X2	$\pm 5\text{ V}$
	0	1	0	X4	$\pm 2.5\text{ V}$
	0	1	1	X8	$\pm 1.25\text{ V}$
	1	0	0	X16	$\pm 0.625\text{ V}$
	0	0	0	X1	X
20V & Uni-polar	0	0	1	X2	0 ~ +10 V
	0	1	0	X4	0 ~ +5 V
	0	1	1	X8	0 ~ +2.5 V
	1	0	0	X16	0 ~ +1.25 V

Note: Please refer section 2.6 for jumper setting of input range.

4

Operation Theorem

The operation theorem of the functions on ACL-8113A card is described in this chapter. The operation theorem can help you to understand how to manipulate or to program this card.

Before programming the ACL-8113A to perform the A/D conversion, you should understand the following issues:

- A/D conversion procedure
- A/D signal source control
- A/D trigger source control
- A/D data transfer mode
- A/D data format

4.1 A/D Conversion Procedure

For using the A/D converter, users must know about the property of the signal to be measured at first. Then users should define and control the A/D signal sources, including the A/D channel, A/D gain, and A/D signal types. Please refer to section 4.2. For A/D signal source control.

After deciding the A/D signal source, the user must decide how to trigger the A/D conversion and define/control the trigger source. The A/D converter will start to convert the signal to a digital value when a trigger signal is rising. Refer to the section 4.3.

The A/D data should be transferred into PC's memory for further using or processing. The data can be read by I/O instruction. To process A/D data, programmer should know about the A/D data format. Refer to section 4.4 for details.

4.2 A/D Signal Source Control

To control the A/D signal source, the signal type, signal channel and signal range should be considered.

Signal Type

The A/D signal sources of ACL-8113A could be single ended (SE) only. The single-ended mode has only one input relative to ground and it suitable for connecting with the floating signal source. The floating source means it does not have any connection to ground. The following figure shows the single-ended connection. Note that when more than two floating sources are connected, the sources must be with common ground.

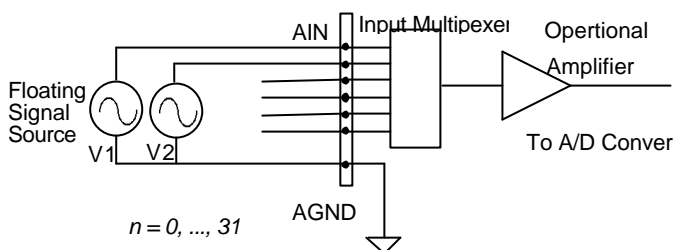

Signal Conditioning

There are 32 SE A/D channels on board. The R/C filters (attenuators) are on board for every channel. The RC circuits for each channel are shown in the following diagram, where 'n' is the channel number. User can install the R, C for special purpose such as attenuating the voltage to increase the input voltage range.

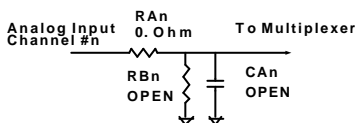

The RC network can also be used as current sensor, which transfers the current into voltage. To get the ground reference level, user can cut-off R_A and let $R_B = 0$ Ohm, thus grounding the input signal. The users can use the ground input to calibrate the offset voltage by software.

Signal Channel Control

The value of AD channel Control register defines the channel to be selected.

Signal Range

The proper signal range is important for data acquisition. The input signal may be saturated if the A/D gain is too large. Sometimes, the resolution may be not enough if the signal is small. The maximum A/D signal range of ACL-8113A is ± 10 volts when the A/D gain value is 1. The A/D gain control register controls the maximum signal input range. The signal gain is programmable with 5 levels (1,2,4,8,16). The signal range of the 32 channels will be identical. The available signal polarities on ACL-8113A could be bi-polar and uni-polar configuration.

4.3 A/D Trigger Source Control

The A/D conversion is started by a AD conversion trigger source, and then the A/D converter will start to convert the signal to a digital value. In ACL-8113A, the only trigger source is software trigger. That is, the A/D conversion is starting when any value is written into the software trigger register. This trigger mode is suitable for low speed A/D conversion. Under this mode, the timing of the A/D conversion is fully controlled by software. However, it is difficult to control the fixed A/D conversion rate unless another timer interrupt service routine is used to generate a fixed rate trigger.

4.4 A/D Data Conversion

A/D Data Transfer Modes

The A/D data are buffered in register, the software must read out the A/D data after the DRDY bit goes “low” after software triggers the A/D.

A/D Conversion Sequence

In ACL-8113A, the A/D conversion can only be controlled by software based on polling concept. That is, the A/D conversion trigger is issued by software, and then checks the DRDY bit (Data Ready Bit) of the A/D status register. If the DRDY=1, the data conversion is still in progress. When the DRDY bit becomes 0 (Low), i.e. the A/D conversion is completed, and the converted data can be read by your program.

The procedures of how to initiate and convert analog input to digital data is listed step by step as following:

1. Define the base address of ACL-8113A card
e.g.
`Base_addr = 0x220;`
2. Set the desired input channel by MUX control register **Base+ 10**
e.g.
`outportb(Base_addr + 10, 2);`
3. Trigger the A/D conversion by writing any data to **Base+12**
e.g.
`outportb(Base_addr + 12, 0);`
4. Wait until the DRDY bit has become low
e.g.
`do status = inport(Base_addr + 5);
while(status & 0x10) == 0x10);`
5. Get the converted data from **Base+4** and **Base+5**
e.g.
`lowByte = inportb(Base_addr + 4);
highByte = inportb(Base_addr + 5) & 0x0f;`
6. Convert binary data to an integer value
e.g.
`Data = lowByte + highByte * 256;`

A/D Data Format

The range of A/D data read from the FIFO port is from 0 to 4095. As the A/D gain is 1, the A/D signal range is roughly -10V ~ +10V or -5V~+5V (bi-polar) and 0V~+10V (uni-polar). The relationship between the voltage and the value is shown in the following table:

A/D Data (Hex) Direct Binary	Unsigned Decimal Value	Voltage (Volts)		
		Bipolar		Uni-polar
		±10V	±5V	0~10V
FFF	4095	+9.9951	+4.9975	+9.9951
C00	3072	+5.0000	+2.5000	+7.5000
801	2049	+0.0049	+0.0025	+5.0049
800	2048	0.0000	0.0000	+5.0000
7FF	2047	-0.0049	-0.0025	+4.9951
400	1024	-5.0000	-2.5000	+2.5000
000	0	-10.0000	-5.0000	0.0000

The formula between the A/D data and the analog value is Direct Binary Coding:

Bipolar ±10V:

$$\text{Voltage} = (\text{AD_Data} * 20) / (4096 * \text{gain}) - (10 / \text{gain})$$

Bipolar ±5V:

$$\text{Voltage} = (\text{AD_Data} * 10) / (4096 * \text{gain}) - (5 / \text{gain})$$

Uni-polar +10V:

$$\text{Voltage} = (\text{AD_Data} * 10) / (4096 * \text{gain})$$

where the **gain** is 1,2,4,8,16

5

C/C++ Library for DOS

This chapter describes the DOS software library, which is free supplied. The DOS library software includes a utility program, C language library, and some demonstration programs, which can help you reduce the programming work.

To program in Windows environment, please use ACLS-DLL2. The function reference manual of ACLS-DLL2 is included in the ADLINK CD. It needs license.

The DOS library includes 6 C-language functions. The functionality of these function calls can be classified to the following capabilities,

1. Initialization: setups the hardware base I/O address and switches different cards.
2. A/D conversion: performs analog to digital conversion.

In addition to the library, some demonstration programs are also provided; you can refer it and save a lot of programming time and get some other benefits as well.

5.1 Installation

To install the DOS library software and utilities, please follow the following installation procedures:

Put *ADLINK CD* into the appropriate CD-ROM drive.

Type the following commands to change to the card's directory (*X* indicates the CD-ROM drive):

```
X:\>CD \NuDAQISA8113
```

Execute the setup batch program to install the software:

```
X:\NuDAQISA\8113>SETUP
```

5.2 C Language Library

The ACL-8113A's analog-to-digital conversion library was constructed to provide a simple programming interface for communicating with the ACL-8113A card. The library provides easy to use functions which allow programmers to use the features of the card in a high-level way.

The version of this library included in the diskette is DOS only. To be compatible with the various compilers, you can compile the source of the library, which also included in the diskette. Borland C and Microsoft C are currently supported. The detailed functions are described in the following sections:

5.3 _8113_Initial

Description

An ACL-8113A card is initialized according to the card number and the corresponding base address. Every ACL-8113A 32-channel A/D Card have to be initialized by this function before calling other functions.

Syntax

```
int _8113_Initial(int card_number, int base_address )
```

Argument

card_number: The card number to be initialized, up to **eight** cards can be initialized in one system, the card number must be 0,..., 7.

base_address: this parameter tells the library which I/O base address is jumper selected on the card. Please refer to I/O base address setting of ACL-8113A.

Return Code

```
ERR_NoRrror  
ERR_InvalidBoardNumber  
ERR_BaseAddressError
```

Example

```
#include "8113.h"  
main()  
{  
    int ErrCode;  
  
    Errcode = _8113_Initial( CARD_1, 0x220 );  
    if( ErrCode != NoError )  
    {  
        printf( " The initializtion of ACL-8113A card is  
failed \n");  
        printf( " Base Address is 0x220 \n");  
        exit(0);  
    }  
  
    ErrCode = _8113_Initial( CARD_2, 0x230 );  
    if( ErrCode != NoError )exit(0);  
  
    .  
    .  
}
```

5.4 _8113_ActCard_Set

Description

This function is used to switch active card which the A/D operations can be applied. After more than one cards are initialized by the function `_8113_Initial`, you have to use this function to select which card is activate currently.

Note: In this library, up to eight ACL-8113A cards can be initialized.

Syntax

```
int _8113_ActCard_Set( int card_number)
```

Argument

`card_number`: The card number must be initialized; up to 8 cards can be initialized in one system. The valid vaule is from 0 to 7.

Return Code

```
ERR_NoRrerror  
ERR_InvalidBoardNumber  
ERR_BaseAddressError
```

Example

```
#include "8113.h"  
  
main()  
{  
    _8113_Initial( CARD_1, 0x210 );  
    _8113_Initial( CARD_2, 0x220 );  
    /* Assume NoError when Initialize ACL-8113A */  
  
    _8113_ActCard_Set( CARD_1 );  
    /*..... You can perform certain functions to Card_1  
    here*/  
  
    _8113_ActCard_Set( CARD_2 );  
    /*..... You can perform certain functions to Card_2  
    here*/  
}
```

5.5 `_8113_Channel_Select/Deselect`

Description

The library functions that do the A/D conversions on multiple channels at once. You may select multiple channels to do the conversions on. The channels are not necessary to select as contiguous, i.e. the channels can be selected in any order, but the conversion sequence will be done in numerical order. The following functions are used to support A/D channel selection and deselection.

- `_8113_Channel_Select`: selects a particular channel for conversion.
- `_8113_Channel_Deselect`: removes a channel from the list of selected channels.
- `_8113_Channel_Clear`: clears all the channels from the list of selected list, and no channel is selected.
- `_8113_ChannelNo_Get`: returns the number of selected channels.

Syntax

```
int _8113_Channel_Select( int channel )
int _8113_Channel_Deselect( int channel )
int _8113_Channel_Clear( void )
int _8113_ChannelNo_Get( int *no )
```

Argument

channel: channel number to perform A/D conversion
(0 ... 31)

Return Code

```
ERR_NoRrror
ERR_InvalidBoardNumber
ERR_BaseAddressError
```

Example

```
#include "8113.h"

main()
{
    _8113_Initial( CARD_1, 0x220 );
    /* Assume NoError when Initialize ACL-8113A */

    _8113_ActCard_Set( CARD_1);
    /* select CARD_1 as active card */

    _8113_Channel_Select( 3 );
}
```

```

printf( "AD channel 3 is now selected.\n" );

_8113_Channel_Select( 5); /* channel 5 is selected */
_8113_Channel_Select( 7); /* channel 7 is selected */
.
.
_8113_MAD_Acquire( );
/* The analog signals in channel 3, 5 and 7 will be converted
   to digital data and save in the Data8113[3], Data8113[5],
   and Data8113[7] */
.
.
..

_8113_Channel_Clear();
/* all the channels in the selected list are removed */
}

```

5.6 _8113_Gain_Select

Description

This function is used to set the A/D gain by means of software. The initial value of gain is $\times 1$ which is set by the ACL-8113A hardware. The relationships between gain and input voltage ranges are specified by following tables:

When input voltage range is set +10V(JP1) and Bipolar mode(JP2), the relationship between gain and input voltage range is listed in the following table.

Input Range (V)	Gain	Gain Code
± 5 V	X 1	AD_GAIN_1
± 2.5 V	X 2	AD_GAIN_2
± 1.25 V	X 4	AD_GAIN_4
± 0.625 V	X 8	AD_GAIN_8

When input voltage range is set +10V(JP1) and Uni-polar mode(JP2), the relationship between gain and input voltage range is listed in the following table.

Input Range (V)	Gain	Gain Code
0 ~ 10 V	X 1	AD_GAIN_1
0 ~ 5 V	X 2	AD_GAIN_2
0 ~ 2.5 V	X 4	AD_GAIN_4
0 ~ 1.25 V	X 8	AD_GAIN_8

Syntax

```
int _8113_Gain_Select (int gain_code )
```

Argument

gain_code: the programmable gain of A/D conversion, the possible values are:

```
AD_GAIN_1, AD_GAIN_2, AD_GAIN_4,  
and AD_GAIN_8.
```

Return Code

```
ERR_NoRrror  
ERR_InvalidBoardNumber  
ERR_BaseAddressError
```

Example

```
#include "8113.h"  
  
main()  
{  
  
    _8113_Initial( CARD_1, 0x220 );  
    /* Assume NoError when Initialize ACL-8113A */  
  
    _8113_Gain_Select( AD_GAIN_8 );  
    printf( "The gain of AD channels is now 8  
times.\n" );  
    /* If the input range is bipolar, then the analog  
voltage is bewteen ± 0.625V */  
    ...  
}
```

5.7 _8113_AD_Acquire

Description:

This function is used to poll the AD conversion data from a specified channel. It will trigger the AD conversion, and read the 12 bits A/D data until the data is ready ('data ready' bit is become to low).

It is a special A/D conversion function, if you do not want to get converted data from the selected channels list.

Syntax:

```
int _8113_AD_Aquire( int channel, int *ad_data )
```

Argument

channel: converted channel no.
ad_data: 12 bits A/D converted value, the value should within 0 to 4095.

Return Code

NoError
Board_No_Init
AD_Aquire_Time_Out

Example

```
#include "8113.h"
main()
{
    int ad_data;
    int ErrCode;

    _8113_Initial( CARD_1, 0x220 );
    /* Assume NoError when Initialize ACL-8113A */

    _8113_ActCard_Set( CARD_1);

    /* converter channel 3 to digital data */
    ErrCode = _8113_AD_Aquire( 3, &ad_data );

    if( ErrCode == NoError )
        printf( "The AD value is %d.\n", ad_data );
    else
        printf( "AD conversion error happen\n" );
}
```

5.8 _8113_MAD_Acquire

Description

This function does one A/D conversion on each of the selected channels, and puts the data in the array call 'Data_8113', which is defined in the file "8113.h". The data array is defined as:

```
extern unsigned Data_8113[31];
```

If the channels in the selected list are 3, 8, 9, and 15, then the converted values for channel 3 will be stored in Data_8113[3], channel 8 in Data_8113[8], ..., etc.

Syntax

```
int _8113_MAD_Acquire( )
```

Return Code

```
ERR_NoRrror  
ERR_InvalidBoardNumber  
ERR_BaseAddressError
```

Example

```
#include "8113.h"  
main()  
{  
  
    _8113_Initial( CARD_1, 0x220 );  
    /* Assume NoError when Initialize ACL-8113A */  
  
    _8113_ActCard_Set( CARD_1);  
    /* select CARD_1 as active card */  
  
    _8113_Channel_Select( 3 );  
    printf( "AD channel 3 is now selected.\n" );  
  
    _8113_Channel_Select( 5); /* channel 5 is selected */  
    _8113_Channel_Select( 7); /* channel 7 is selected */  
    .  
    .  
    _8113_MAD_Acquire( );  
    /* The analog signals in channel 3, 5 and 7 will be  
       converted to digital data and save in the Data-  
       _8113[3], Data_8113[5], and Data_8113[7] */  
    .  
    .  
    ..  
    _8113_Channel_Clear();  
    /* all the channels in the selected list are removed */  
}
```

6

Calibration

In data acquisition process, how to calibrate your measurement devices to maintain its accuracy is very important. This chapter will guide you to calibrate your ACL-8113A to an accuracy condition.

6.1 What do you need

Before calibrating your ACL-8113A card, you should prepare some equipment for the calibration:

1. Calibration program: once the program is executed, it will guide you to do the calibration. This program is included in the delivered package.
2. one 6 1/2 digit multimeter.
3. a voltage calibrator or very stable and noise free DC voltage generator.

6.2 VR Assignment

There are four variable resistors (VR) on the ACL-8113A board to allow you making accurate adjustment on A/D and D/A channels. The functionality of each VR is listed below:

VR1	A/D Bipolar offset adjustment
VR2	A/D Bipolar full-scale adjustment
VR3	Programmable amplifier offset adjustment
VR4	A/D Bipolar full-scale adjustment

6.3 Bipolar A/D Adjustment

1. Set jumper JP1 to "**10V**" and JP2 to "**BI**" position.
2. Short the A.GND and AI0 (Channel 0 analog input).
3. Trim **VR3** until the reading of the A/D conversion data flickers between 2047 and 2048.
4. Trim the **VR1** until the reading of the A/D conversion data flickers between 2047 and 2048.
5. Set Gain as x1, and applied +5V voltage to AI0. Adjust **VR2** until the reading of the A/D conversion data flickers between 4094 and 4095.

6.4 Uni-polar A/D Adjustment

1. Set jumper JP1 to "**10V**" and JP2 to "**UN**" position.
2. Short the A.GND and AI0 (Channel 0 analog input).
3. Trim the **VR3** until the reading of the A/D conversion data flickers between 0000 and 0001.
4. Set Gain as x1, and applied +10V voltage to AI0. Adjust **VR4** until the reading of the A/D conversion data flickers between 4094 and 4095.

Product Warranty/Service

ADLINK warrants that equipment furnished will be free from defects in material and workmanship for a period of one year from the date of shipment. During the warranty period, we shall, at our option, either repair or replace any product that proves to be defective under normal operation.

This warranty shall not apply to equipment that has been previously repaired or altered outside our plant in any way as to, in the judgment of the manufacturer, affect its reliability. Nor will it apply if the equipment has been used in a manner exceeding its specifications or if the serial number has been removed.

ADLINK does not assume any liability for consequential damages as a result from our product uses, and in any event our liability shall not exceed the original selling price of the equipment. The remedies provided herein are the customer's sole and exclusive remedies. In no event shall ADLINK be liable for direct, indirect, special or consequential damages whether based on contract or any other legal theory.

The equipment must be returned postage-prepaid. Package it securely and insure it. You will be charged for parts and labor if the warranty period is expired or the product is proven to be misuse, abuse or unauthorized repair or modification.